



1.1 1-1

1.2 1-3



1.

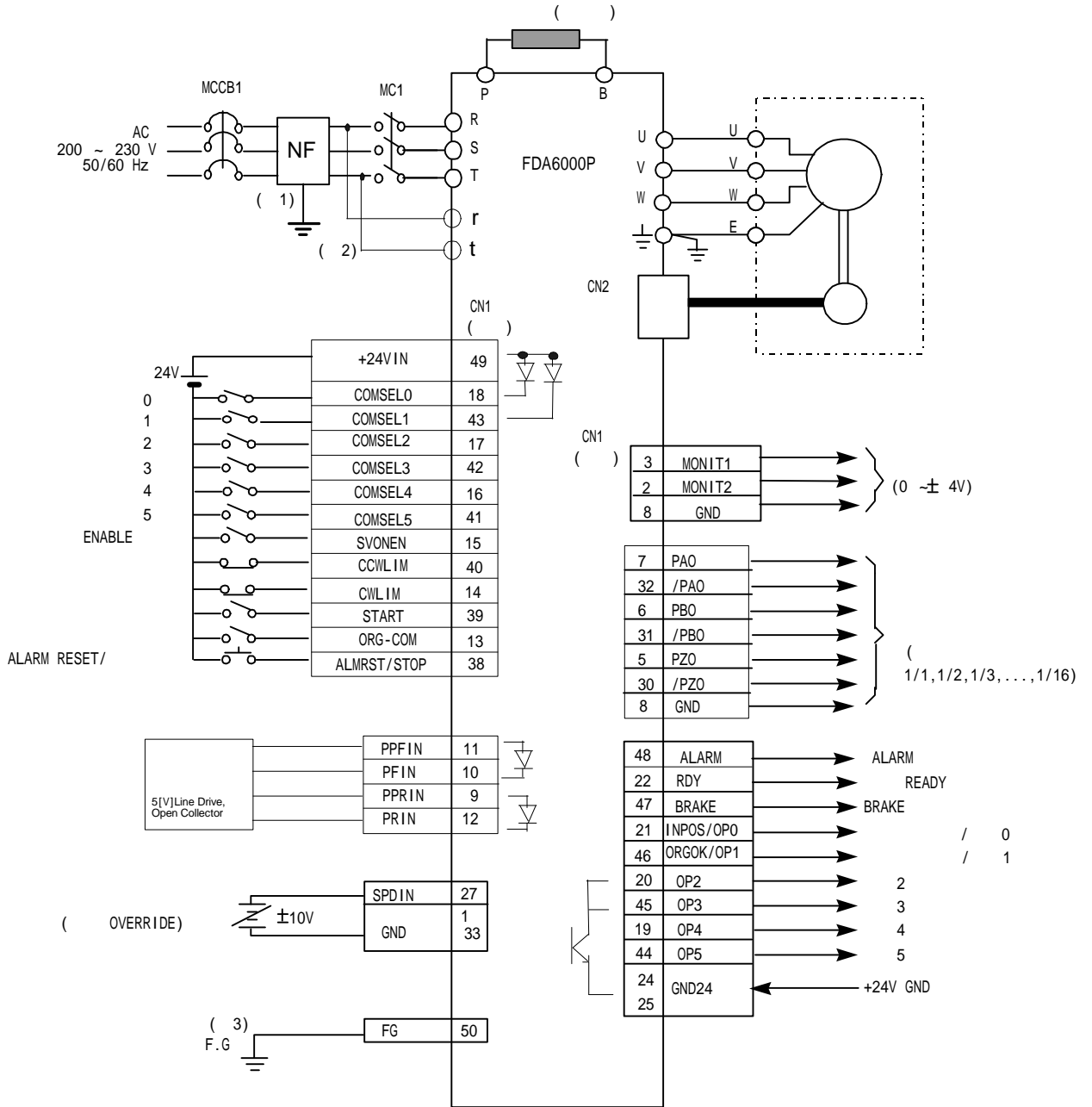

**)

START(41)	FDA6000C	ORG_DOG(39)	START
5	COMSEL5	ORGOK	

2. P8-01=3,4

64 DATA COMSEL0 ~ COMSEL3 16 Group
 Group 4 DATA , OP0~OP5
 DATA 64
 OFF=>ON OFF=>ON
 4
 1,2,3,4 1,2,3 OFF=>ON

COM SEL0	COM SEL1	COM SEL2	COM SEL3	DATA	OFF=>ON
0	0	0	0	P5-01=>P5-17=>P5-33=>P5-49	P5-49
1	0	0	0	P5-02=>P5-18=>P5-34=>P5-50	P5-50
0	1	0	0	P5-03=>P5-19=>P5-35=>P5-51	P5-51
1	1	0	0	P5-04=>P5-20=>P5-36=>P5-52	P5-52
0	0	1	0	P5-05=>P5-21=>P5-37=>P5-53	P5-53
1	0	1	0	P5-06=>P5-22=>P5-38=>P5-54	P5-54
0	1	1	0	P5-07=>P5-23=>P5-39=>P5-55	P5-55
1	1	1	0	P5-08=>P5-24=>P5-40=>P5-56	P5-56
0	0	0	1	P5-09=>P5-25=>P5-41=>P5-57	P5-57
1	0	0	1	P5-10=>P5-26=>P5-42=>P5-58	P5-58
0	1	0	1	P5-11=>P5-27=>P5-43=>P5-59	P5-59
1	1	0	1	P5-12=>P5-28=>P5-44=>P5-60	P5-60
0	0	1	1	P5-13=>P5-29=>P5-45=>P5-61	P5-61
1	0	1	1	P5-14=>P5-30=>P5-46=>P5-62	P5-62
0	1	1	1	P5-15=>P5-31=>P5-47=>P5-63	P5-63
1	1	1	1	P5-16=>P5-32=>P5-48=>P5-64	P5-64

DATA	OP0	OP1	OP2	OP3	OP4	OP5
P5-01	0	0	0	0	0	0
P5-02	1	0	0	0	0	0
P5-03	0	1	0	0	0	0
P5-04	1	1	0	0	0	0
P5-05	0	0	1	0	0	0
~ - ~			~ - ~			
P5-60	1	1	0	1	1	1
P5-61	0	0	1	1	1	1
P5-62	1	0	1	1	1	1
P5-63	0	1	1	1	1	1
P5-64	1	1	1	1	1	1