

SIEMENS



SIMOTICS 1LE0003 超高效低压交流异步电动机

SIMOTICS 1LE0003 Premium efficiency Low-voltage Motors

2015.11

Answers for industry.



目录

Contents

总体介绍 Overview	3
参考标准 Reference standards	5
机械特性 Mechanical design	6
电气特性 Electrical design	14
变频应用 Converter fed application	18
订货号 Order No.	20
选型技术数据表 Technical data table	22
选件 Options	30
外形尺寸 Dimension drawings	34
认证 Certificates	39



总体介绍

SIMOTICS 1LE0003 系列超高效低压电动机是铸铁机壳通用型全封闭自扇冷却或强制冷却式三相异步电动机，其防护等级为 IP55，该系列电动机设计生产符合 ISO、IEC、GB 等相关标准的要求。

SIMOTICS 1LE0003 系列超高效低压电动机适用于连续工作制（S1）、恒转速或一定速度范围内的变频调速应用。

技术特性

- 机座材料：灰铸铁；
- 标准颜色：石头灰（RAL 7030）；
- 额定功率：0.55kW~200kW（50Hz）
- 0.75kW 及以上的 2、4、6 极电动机达到 GB18613-2012 标准能效等级 2 级，且能满足 IEC 60034-30 标准中的 IE3 效率等级（50Hz）；
- 优化的紧凑型结构；
- 标准安装结构类型（符合 IEC 60034-7 标准规定）：IM B3、IM B5、IM B35 等；
- 所有的电动机设计防护等级为 IP55（IEC 60034-5）；
- FS¹⁾ 280 ~ 315 标配再润滑装置，FS¹⁾ 100 ~ 250 的作为选项；
- 对于 FS 100 ~ 315 范围电动机，可选择增强悬臂力设计；
- 电动机可选 PTC 或 PT100 热敏电阻或 KTY84-130 进行绕组保护；

¹⁾ FS，机座的英文（Frame Size）缩写。

Overview

SIMOTICS 1LE0003 low voltage premium efficiency motor with cast iron housing is Totally Enclosed Fan Cooled (TEFC) or Totally Enclosed Forced Ventilated with IP55 environmental protection, and applicable for general purpose use. These motors are designed and manufactured in accordance with ISO, IEC standards, GB standards.

SIMOTICS 1LE0003 low voltage premium efficiency motor is designed for constant or adjustable speed with continuous duty operation (S1) over a speed range.

Features

- Frame material: grey cast iron.
- Standard color: stone grey (RAL 7030)
- Rated power output: 0.55kW~200kW at 50Hz.
- Available in 2, 4, 6 pole motor (0.75kW and up) with efficiency grade 2. according to GB18613-2012 and efficiency class IE3 (50Hz) according to IEC 60034-30.
- Optimized compact style construction.
- Standard mounting construction according to IEC 60034-7: IM B3, IM B5, IM B35 and etc.
- All motors are designed to IP55 degree of protection (IEC 60034-5).
- Re-greasing devices for FS¹⁾ 280 ~ 315 as standard, and for FS100 ~ 250 as option.
- Reinforced bearings for increased cantilever forces for FS100 ~ 315 as option.
- Winding protections with PTC, PT100 and KTY84-130 as option.

¹⁾ FS，Frame Size

- 接线盒标准位置处于机座顶端，进线孔处于 右侧（从驱动端看），选项中接线盒位置和进线方向可变化；
- 绝缘系统按 155 (F) 温度等级设计，在额定输出和直接供电时按 130 (B) 温度等级使用；
- 电动机标准冷却方式为自扇冷却（IEC 60034-6 规定的 IC 411），可提供独立驱动风扇强制冷却；
- FS 100 ~ 315 电动机都有 2 个吊环，FS80~90 电动机没有吊环。
- Terminal box on top, and cable entry on right side (viewed from driven end). Variable location of connection boxes and cable entries as option.
- Insulation system is designed for temperature class 155 (F). At rated output with line-fed operation, the motors can be used in temperature class 130 (B).
- Self ventilated motors with radial-flow fans (cooling method IC 411 according to IEC 60034-6) as standard, forced air cool with external separately driven fans as option.
- FS 100 ~ 315 all motors have 2 eyebolts. FS80~90motor donot have eyebolt;

运行环境

- 防护等级 IP55（IEC 60034-5）；
- 高度不超过海拔 1000 m（IEC 60034-1）；
- 允许的环境温度在 -20 °C ~ 40 °C（IEC 60034-1）；
- 所允许的相对湿度：
 - -20 °C ≤ T ≤ 20 °C：100 %
 - 20 °C < T ≤ 30 °C：95 %
 - 30 °C < T ≤ 40 °C：55 %

对于更高的环境温度、以及（或者）高于海拔 1000 m 的地点，电动机的额定功率换算系数为 k_{HT} 。所允许的功率值 (P_{adm})：

$$P_{adm} = P_{rated} \cdot k_{HT}$$

Environmental

- Degrees of motor protection IP55 (IEC 60034-5).
- Altitude shall not exceed 1000m above sea-level (IEC 60034-1).
- Allowed air temperature between -20 °C and 40 °C (IEC 60034-1).
- Permitted relative humidity:
 - -20 °C ≤ T ≤ 20 °C：100 %
 - 20 °C < T ≤ 30 °C：95 %
 - 30 °C < T ≤ 40 °C：55 %

For higher coolant temperatures and / or site altitudes higher than 1000 m above sea level, the specified motor output must be reduced by using the factor k_{HT} . The results in an admissible output (P_{adm}) of the motor:

$$P_{adm} = P_{rated} \cdot k_{HT}$$

对于不同高度和（或）不同环境温度的功率换算系数 k_{HT} Factor k_{HT} for different site altitudes and / or coolant temperature						
海拔高度 Site altitude above see level	对应海拔高度的环境温度 Site altitude above see level Coolant temperature					
	< 30 °C	30 ~ 40 °C	45 °C	50 °C	55 °C	60 °C
1000 m	1.07	1.00	0.96	0.92	0.87	0.82
1500 m	1.04	0.97	0.93	0.89	0.84	0.79
2000 m	1.00	0.94	0.90	0.86	0.82	0.77
2500 m	0.96	0.90	0.86	0.83	0.78	0.74
3000 m	0.92	0.86	0.82	0.79	0.75	0.70
3500 m	0.88	0.82	0.79	0.75	0.71	0.67
4000 m	0.82	0.77	0.74	0.71	0.67	0.63

电动机符合下面的电气和机械标准：

Standards:

名称 Title	IEC 标准 IEC standard	中国国家标准 Chinese standard
旋转电动机定额和性能 Rotating electrical machines – Part 1: Rating and performance	IEC 60034-1	GB 755
旋转电动机损耗与效率确定的标准测试方法 Rotating electrical machines – Part 2-1: Standard methods for determining losses and efficiency from tests (excluding machines for traction vehicles)	IEC 60034-2	GB/T 1032
旋转电机整体结构的防护等级 (IP 代码) 分级 Rotating electrical machines – Part 5: Degrees of protection provided by the integral design of rotating electrical machines (IP code) - Classification	IEC 60034-5	GB/T 4942.1
旋转电动机冷却方法 Rotating electrical machines – Part 6: Methods of cooling (IC Code)	IEC 60034-6	GB/T 1993
旋转电动机结构型式、安装型式及接线盒位置的分类 (IM 代码) Rotating electrical machines – Part 7: Classification of types of construction, mounting arrangements and terminal box position (IM Code)	IEC 60034-7	GB/T 997
旋转电动机旋转电机线端标志与旋转方向 Rotating electrical machines – Part 8: Terminal markings and direction of rotation	IEC 60034-8	GB/T 1971
旋转电机噪声测定方法及限值 第 3 部分：噪声限值 Rotating electrical machines – Part 9: Noise limits	IEC 60034-9	GB 10069.3
轴中心高为 56 mm 及以上电机的机械振动 振动的测量、评定及限值 Rotating electrical machines – Part 14: Mechanical vibration of certain machines with shaft heights 56 mm and higher – Measurement, evaluation and limits of vibration severity	IEC 60034-14	GB 10068
旋转电机尺寸和输出功率等级 第 1 部分：机座号 56 ~ 400 和凸缘号 55 ~ 1080 Rotating electrical machines – Part 1: Frame numbers 56 to 400 and flange numbers 55 to 1080	IEC 60072-1	GB/T 4772.1
中小型旋转电机安全要求 Safety requirements of small and medium size rotating electrical machines		GB 14711
旋转电动机温升 Electrical insulation – Thermal classification	IEC 60085	GB/T 11021
电工电子产品自然环境条件 温度和湿度 Classification of environmental conditions Part 2-1: Environmental conditions appearing in nature – Temperature and humidity	IEC 60721-2-1	GB/T 4797.1
标准电压 Standard voltages	IEC 60038	GB/T 156

铭牌信息 Nameplate

1	2	3	4	5	6	7	8	9	10	11	12	13	14	15	16	17	18	19	20	21	22	23	24	25	26	27
3-Mot. 0CV3352B		355M	IMB3	IP55	1550	kg	LMH- 1406 / 800003888993 / 001																			
V	Hz	kW	A	EFF.	cos φ	r/min	EFF Cl.																			
380△/660Y	50	220	385/225	95.0%	0.90	1490	IE3																			
440△	60	246	375	95.0%	0.90	1790																				
BRG DE 6322 C3		BRG INDE 6322 C3					Th. Cl. 155(F)																			
GREASE Unirex N3							IEC60034-30																			
Re-grease interval :4000h		Quantity, 50g					GB18613-2012 Eff.-Grade2																			
1LE0003-3SB23-3AA4-Z							Q/321081 KJA006-2014																			

- | | |
|-------------|---------------------------------------|
| 1 三相异步电动机 | Three-phase low-voltage motor |
| 2 订货号 | Order No. |
| 3 型号 | Type |
| 4 产品序列号 | Series number |
| 5 安装结构形式 | Type of construction |
| 6 防护等级 | Degree of protection |
| 7 额定电压 | Rated voltage and Winding connections |
| 8 频率 | Frequency [Hz] |
| 9 额定功率 | Rated output [kW] |
| 10 额定电流 | Rated current [A] |
| 11 效率 | Efficiency |
| 12 功率因数 | Power factor [cos φ] |
| 13 额定转速 | Rated speed |
| 14 绝缘耐热等级 | Thermal class |
| 15 驱动端轴承 | Bearing at the drive end |
| 16 润滑脂类型 | Grease type |
| 17 再润滑周期 | Re-grease interval |
| 18 执行标准 | Standards |
| 19 再加润滑脂的重量 | Quantity |
| 20 非驱动端轴承 | Bearing at the non-drive end |
| 21 中国国家标准 | GB standard |
| 22 净重 | Net weight |
| 23 中国能效等级 | GB efficiency grade |
| 24 机座号 | Frame size |
| 25 平衡方式 | Balance method |
| 26 IEC 标准 | IEC standard |
| 27 IEC 能效等级 | IEC efficiency class |

机械特性

接线盒

接线盒标准位置处于机座顶端，且自身可 4×90° 旋转安装，从而使电缆可以从各个方向进入。所有接线盒都有两个进线孔，其中一个进线孔采用葛兰密封，另一个进线孔采用螺塞密封。



Mechanical design

Connection box

The connection box is located on the top of motor housing as standard, and can be rotated by 4×90° to allow for cable entry from each direction. All the connection box have 2 cable entries, one is sealed by the cable gland, and another sealed by screwed plug.



接线盒技术参数

机座号 Frame Size	主接线端子数 Number of main terminals	最多可容纳的辅助端子数 Max. allowable auxiliary terminals	接线螺钉螺纹 Contact screw thread	引接线最大截面积 (mm ²) Max. connectable cross-section	外接电缆直径 (mm) Outer cable diameter (sealing range)	进线孔尺寸 (葛兰 + 螺塞) Cable entry size (Gland+Screwed plug)
80	6	12	M4	1.5	13~18	M25*1.5+M16*1.5
90	6	12		1.5		
100	6	12		4		
112	6	12		4		
132	6	12		6	18~25	M32*1.5+M32*1.5
160	6	14	M5	16	22~32	M40*1.5+M40*1.5
180	6	14	M5	16	22 ~ 32	M40×1.5+M40×1.5
200	6	14 ¹⁾	M6	25	32 ~ 38	M50×1.5+M50×1.5
225	6	14 ¹⁾	M8	35		
250	6	14 ¹⁾	M10	120	37 ~ 44	M63×1.5+M63×1.5
280	6	14 ¹⁾		120		
315	6	16 ¹⁾		M12		

Connection boxes technical data

注：¹⁾ 需要的辅助端子数若超过接线盒最多可容纳的辅助端子数时，须选择辅助接线盒（选件号：L97）

Note: ¹⁾ An auxiliary connection box (option code: L97) is required when the total number of auxiliary terminals exceeds the number of allowable terminals in main connection box.

接线盒位置

接线盒除标准位置外，还可处于电动机机座的左侧或右侧。电动机接线盒位置可以在电动机订货号的第 16 位用数字表示出。

Location of the connection box

Besides standard position, the connection box also can be on the right or left of motor housing. The position of terminal box can be indicated on the 16th digit of motor order code.

接线盒的位置是指从电动机驱动端来看的位置。

The position of connection box is described by viewed from drive end (DE).

- 标配接线盒在顶部，电动机订货号的第 16 位数字为 4；
- 接线盒在右边，电动机订货号的第 16 位数字为 5；
- 接线盒在左边，电动机订货号的第 16 位数字为 6。

- On top (Standard), 16th position of Motor Order No. digit 4.
- On RHS, 16th position of Motor Order No. digit 5.
- On LHS, 16th position of Motor Order No. digit 6.

当电动机的接线盒位置与其它部件冲突时，可以将接线盒从驱动端移到非驱动端（选件号：H08）。

If there is interfere between the connection box and other components, the connection box can be moved from the drive end (DE) to non-drive end (NDE) (Option code: H08).

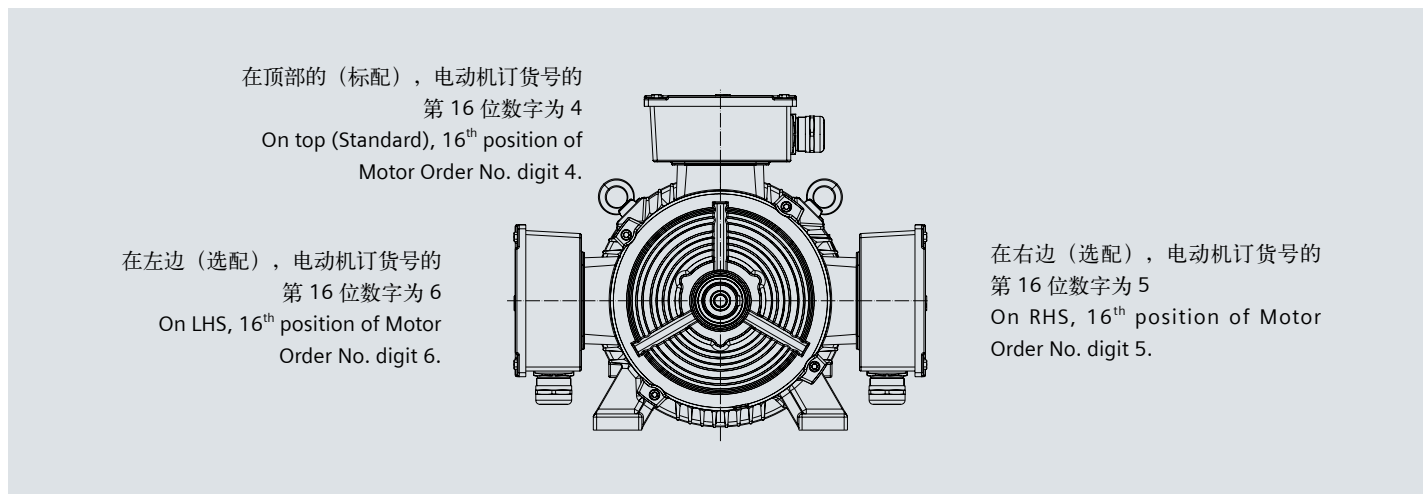

接线盒的进线孔

除非另作规定，否则进线孔的标准位置如下图所示。接线盒可以按照图示的位置旋转。

Cable entry on connection box

Unless stated, otherwise the cable entry is located in the standard position as show in the following illustration. The connection box can also be rotated such that the cable entry is located.

- 朝向驱动端
接线盒旋转 90°，进线口朝向驱动端，选件号为 R10。
对于 FS80 ~ 112 的带法兰（IM B5）电动机，只有接线盒在非驱动（选件号：H08）时，才可以选择进线孔朝向驱动端。
- 朝向非驱动端
接线盒旋转 90°，进线口朝向非驱动端，选件号为 R11。
- 朝向左侧（与标准方向相反）
接线盒旋转 180°，进线口位置相反，选件号为 R12。

- Towards the drive end (DE)
Rotation of connection box by 90°，entry from DE, Option code R10.
For flange motor (IM B5) from FS80 to FS100, only possible with connection box on NDE (Option code H08).
- Towards the non-drive end (NDE)
Rotation of connection box by 90°，entry from NDE, Option code R11.
- Towards the left side (opposite to Standard)
Rotation of connection box by 180°，entry from opposite end, Option code R12.

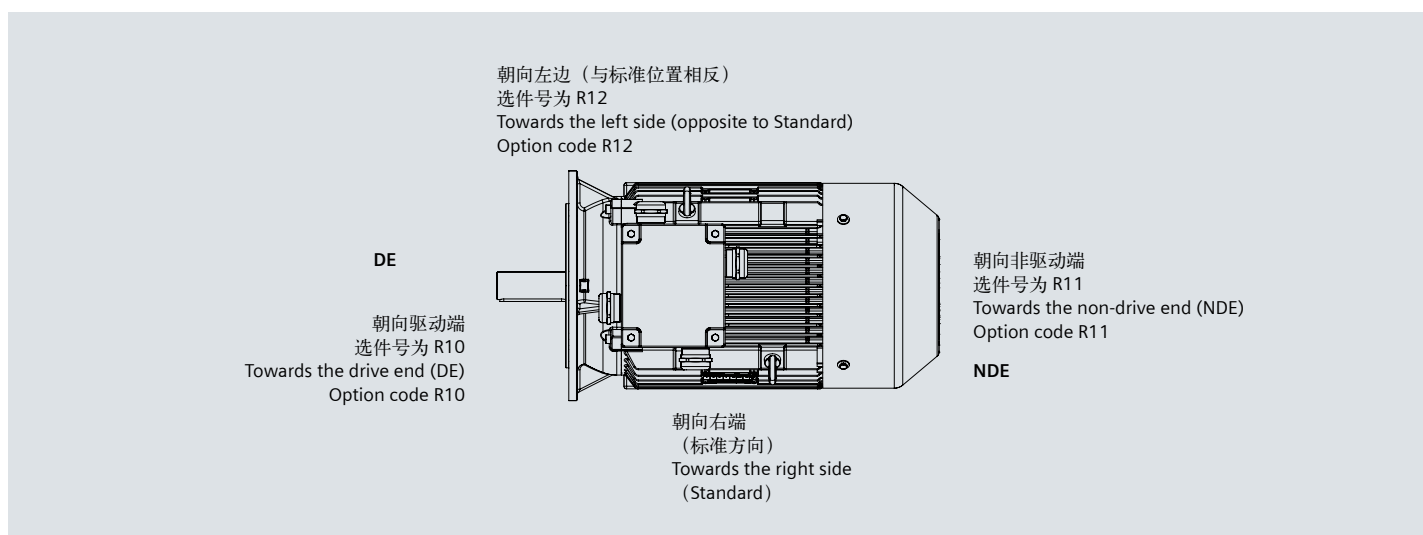

如果接线盒的位置改变时（如右侧或左侧），须要检查进线孔的位置是否方便进线。必要时，可以同时订购其它选件（R10, R11 和 R12）。

If the position of the connection box (connection box RHS or LHS) is changed, the position of the cable entry must be checked. If necessary, it can be ordered with the corresponding order codes (R10, R11 and R12).

安装结构型式 Construction and mounting type

结构型式 Construction type	机座带底脚，端盖无法兰 With feet and without flange on the end-shield (DE)					
安装型式 Mounting type	IM B3 FS 80 ~ 315	IM B6 FS 80 ~ 315	IM B7 FS 80 ~ 315	IM B8 FS 80 ~ 315	IM V5 ¹⁾ FS 80 ~ 315	IM V6 ²⁾ FS 80 ~ 315
示意图 Diagram						
电动机订货号第 14 位号上 对应的字母 Letter, position 14 th of Motor code	A	T	U	V	C	D
结构型式 Construction type	机座不带底脚，端盖有法兰 Without feet and with flange on the end-shield (DE)			机座带底脚，端盖有法兰 With feet and with flange on the end-shield (DE)		
安装型式 Mounting type	IM B5 FS 80 ~ 315	IM V1 ¹⁾ FS 80 ~ 315	IM V3 ²⁾ FS 80 ~ 315	IM B35 FS 80 ~ 315	IM V15 ¹⁾ FS 80 ~ 315	IM V35 ²⁾ FS 80 ~ 315
示意图 Diagram						
电动机订货号第 14 位号上 对应的字母 Letter, position 14 th of Motor code	F	G	H	J	W	Y
结构型式 Construction type	机座不带底脚，端盖有标准小法兰 Without feet and with C-flange on the end-shield (DE)			机座带底脚，端盖有标准小法兰 With feet and with C-flange on the end-shield (DE)		
安装型式 Mounting type	IM B14 FS 80 ~ 160	IM V18 ¹⁾ FS 80 ~ 160	IM V19 ²⁾ FS 80 ~ 160	IM B34 FS 80 ~ 160		
示意图 Diagram						
电动机订货号第 14 位号上 对应的字母 Letter, position 14 th of Motor code	K	M	L	N		

¹⁾ 室外使用时推荐使用护罩（选件号 H00）；

²⁾ 当户外安装时，推荐对电动机轴采取防护措施，避免水直接喷射到电动机轴上。

¹⁾ At outdoor application, the using of protective cover (Option code H00) is recommended

²⁾ At out door application the protection of shaft again jet-water is recommended

冷却与通风

所有电动机标配装有径流（离心）式冷却风扇，其冷却效能与电动机的旋转方向无关（冷却方法符合 IEC60034-6 标准的 IC411）。

对于某些应用，可以考虑配置独立驱动风扇，如，

- 电动机在低速运行时，推荐使用独立驱动风扇，从而使电动机得到有效利用；
- 电动机在明显高于额定同步转速的速度运行时，同样推荐选用独立驱动风扇，这样有助于降低电动机噪声。

独立驱动风扇的选件号为 F70。当安装独立驱动风扇时，电动机的长度将增加 ΔL 。

Cooling and ventilation

The 1LE0003 standard motors are fitted with an radial flow fan for cooling in accordance with IEC 60034-6 cooling method.

For some special application, separately driven fan should be considered to be configured.

- The use of a separately driven fan is recommended to increase motor utilization at low speed;
- When motor speed significantly higher than the synchronous speed, the separately fan is also recommended to be used. It can help reduce the motor noise.

The separately driven fan can be supplied already fitted, Option code F70. When the separately driven fan is mounted, the length of the motor increase by ΔL .

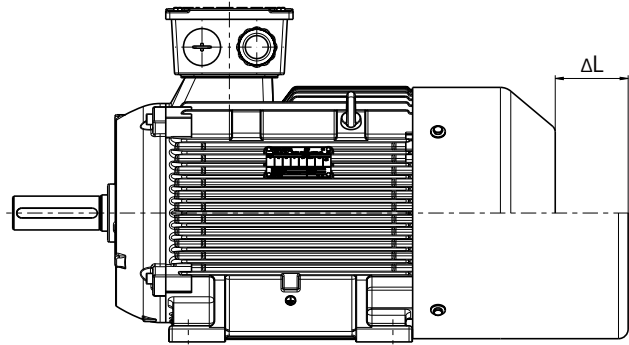

独立驱动风扇技术参数

Technical data for separately fan

对应电动机机座号 Motor frame size	电压 Voltage (V)	频率 Frequency (Hz)	功率 Rated output (W)	电流 Current (A)	转速 Speed (r/min)	Δ L (mm)
80	380V	50	30	0.08	2800	60
90	380V	50	30	0.08	2800	70
100	380V	50	52	0.12	2800	80
112	380V	50	52	0.12	2800	90
132	380V	50	45	0.35	1400	75
160	380V	50	45	0.35	1400	55
180	380V	50	120	0.6	1400	35
200	380V	50	120	0.6	1400	65
225	380V	50	120	0.6	1400	60
250	380V	50	230	1.0	1400	65
280	380V	50	230	1.0	1400	110
315	380V	50	370	1.1	1250	90

注：风扇可以在 210 ~ 240VD/360 ~ 420VY 50Hz 电源供电下运行，也可以在 220 ~ 260VD/380 ~ 480VY 60Hz 电源供电下运行。其他电源供电，须特殊询价。

Note: The fan can be running with supply 210 ~ 240VD/360 ~ 420VY 50Hz, and also 220 ~ 260VD/380 ~ 480VY 60Hz. Other voltage supply, possible on request.

轴承系统

SIMOTICS 1LE0003 系列超高效低压电动机标准配置深沟球轴承或角接触球轴承，这些轴承是密封的或可再润滑型的。

FS80~160 范围的电动机驱动端与非驱动端轴承浮动。

FS180 ~ 315 电动机驱动端轴承浮动，非驱动端轴承固定。

标准配置的轴承可以承受一定的悬臂力，关于悬臂力可以参见第 11 页“电动机轴驱动端允许的最大悬臂力”。当电动机轴端承受的悬臂力较大时，可以考虑选择增强悬臂力的轴承设计（选件号：L22）。

FS80 ~ 250 范围电动机标配不带再润滑装置；FS280 ~ 315 范围的电动机标配可再润滑轴承，并标配再润滑装置。如果需要，FS100 ~ 250 范围的电动机也可选用可再润滑轴承和再润滑装置（选件号：L23）。

Bearing system

SIMOTICS 1LE0003 premium efficiency low voltage motor is supplied with the ball bearing as standard. These bearings are either of the sealed or regreasable type.

For FS80~160, the floating bearings are assembled;

for FS180 ~ 315, floating bearing at DE, and fixed bearing at NDE assembled.

The standard bearing can endure a maximum cantilever force, referred to page 11 - Permissible cantilever forces. If higher cantilever force on the shaft required, the increased cantilever bearing design (Option code: L22) should be considered.

As standard, FS80 ~ 250 motors are not with regreasing device, but FS280 ~ 315 motors with regreasable bearing and regreasing device. If necessary, FS100 ~ 250 motor can be configured with regreasable bearing and regreasing device (Option code: L23).

轴承选配

Bearing Assignment

机座号 Frame size	极数 Pole	标准配置 Standard design			增强悬臂力设计轴承 (选件号: L22) Increased cantilever-bearing (Option code: L22)			再润滑轴承 (选件号: L23) Re-greasing bearing (Option code: L23)	
		驱动端轴承 DE bearing	非驱动端轴承 (水平安装) NDE bearing (Horizontal mounting)	非驱动端轴承 (立式安装) NDE bearing (Vertical mounting)	驱动端轴承 DE bearing	非驱动端轴承 (水平安装) NDE bearing (Horizontal mounting)	非驱动端轴承 (立式安装) NDE bearing (Vertical mounting)	驱动端轴承 DE bearing	非驱动端轴承 NDE bearing
80	2,4,6	6204 2Z C3	6204 2Z C3	6204 2Z C3	-	-	-	-	-
90	2,4,6	6205 2Z C3	6205 2Z C3	6205 2Z C3	-	-	-	-	-
100	2,4,6	6206 2Z C3	6206 2Z C3	6206 2Z C3	6306 2Z C3	6206 2Z C3	6206 2Z C3	6206 C3	6206 C3
112	2,4,6	6206 2Z C3	6206 2Z C3	6206 2Z C3	6306 2Z C3	6206 2Z C3	6206 2Z C3	6206 C3	6206 C3
132	2,4,6	6208 2Z C3	6208 2Z C3	6208 2Z C3	6308 2Z C3	6208 2Z C3	6208 2Z C3	6208 C3	6208 C3
160	2,4,6	6209 2Z C3	6209 2Z C3	6209 2Z C3	6309 2Z C3	6209 2Z C3	6209 2Z C3	6209 C3	6209 C3
180	2,4,6	6210 Z C3	6210 Z C3	6210 Z C3	NU210	6210 Z C3	6210 Z C3	6210 C3	6210 C3
200	2,4,6	6212 Z C3	6212 Z C3	6212 Z C3	NU212	6212 Z C3	6212 Z C3	6212 C3	6212 C3
225	2,4,6	6213 Z C3	6213 Z C3	6213 Z C3	NU213	6213 Z C3	6213 Z C3	6213 C3	6213 C3
250	2,4,6	6215 C3	6215 C3	7215 AC	NU215	6215 C3	O.R.	6215 C3	6215 C3
280	2,4,6	6317 C3	6317 C3	7317 AC	NU317	6317 C3	O.R.	□	□
315	2,4,6	6319 C3	6319 C3	7319 AC	NU319	6319 C3	O.R.	□	□

注:
DE 驱动端
NDE 非驱动端
- 不能满足
□ 标准配置
O.R. 须要特殊询价

Note:
DE Driven end
NDE Non driven end
- Not possible
□ Standard
O.R. Possible on request

轴承寿命 (标称寿命)

轴承的标称额定寿命可根据 ISO 281 标准规定的标准计算程序计算出来的。如果电动机在该样本中所规定条件下运行, 90% 甚至更高比例的轴承的运行时间可达到标称寿命。通常, 轴承的使用寿命取决于轴承规格、轴承载荷、运行条件、转速以及润滑脂寿命。

当电动机水平安装, 且不受轴向力的情况下, 电动机的轴承寿命至少能够达到 40,000 小时。在承受最大容许载荷的情况下, 其寿命也至少有 20,000 小时, 这里所说的轴承寿命, 指的都是电动机在 50 Hz 下正常运行的情况。

当电动机在非正常的条件下运行时, 轴承的寿命会缩短。如下面几种情况:

- 当电动机的运行速度高于额定速度时, 由于电动机的振动增大, 使得轴承受到额外的径向力和轴向力, 导致其寿命减少;
- 当环境或设备等因素引起电动机振动加大时, 同样轴承也会因此受到额外的径向力和轴向力, 而导致其寿命减少;
- 当环境温度每升高 10°C, 润滑脂寿命以及再润滑时间缩短一半。

润滑脂寿命和再润滑周期

对于不可再润滑的轴承, 其润滑脂寿命与轴承寿命相当。但是, 这只能是在电机严格按照本样本中规定的技术数据运行。

对于以规定间隔再润滑的电机, 轴承寿命可以延长, 从而补偿不利因素, 诸如温度、安装条件、转速、轴承规格和机械载荷造成的影响。

Bearing life time (nominal lifetime)

The nominal bearing lifetime is defined according standardized calculation procedures (ISO 281) and is reached or even exceeded for 90% of the bearings when the motors are operated in compliance with the data provide in the catalog. Generally, the bearing lifetime is defined by the bearing size, the bearing load, the operating condition, the speed and the grease lifetime.

The bearing lifetime of motors with horizontal type of construction is at least 40,000 hours if there is no additional axial loading at the coupling output and at least 20,000 hours with the maximum admissible loads. This assumes that the motor is operated at 50Hz.

When the motor runs outside of normal conditions, the bearing life will be reduced, such as the following conditions.

- When the motors runs beyond the rated speed, the increase of motor vibration will result in the extra radial and axial force on bearing. This will reduce the life of bearing;
- When the motor vibration increase due to the environment or other equipment, the bearing also will endure more radial and axial force. This also will reduce the life of bearing;
- If the coolant temperature is increased by 10 °C, the grease lifetime and regreasing interval is halved.

Grease life and re-greasing interval

For permanent lubrication, the bearing grease lifetime is matched to the bearing lifetime. This can, however, only be achieved if the motor is operated in accordance with the catalog specifications.

For motors which can be regreased at defined regreasing intervals, the bearing lifetime can be extended and/or unfavorable factors such as temperature, mounting conditions, speed, bearing size and mechanical load can be compensated.

润滑脂寿命和再润滑周期（电动机水平安装）

Grease life (Horizontal installation)

机座号 Frame size	极数 Poles	润滑脂寿命 Grease lifetime up to CT 40 °C ¹⁾
持久润滑型轴承的润滑脂 Grease for permanent lubrication bearing		
80 ~ 250	2, 4, 6	20000 或 (or) 40000 ²⁾
可再润滑型轴承的润滑脂 Grease for regreasable bearing		
100 ~ 160	2, 4, 6	8000 小时 (h)
180 ~ 250	2	4000 小时 (h)
180 ~ 250	4, 6	8000 小时 (h)
280 ~ 315	2	3000 小时 (h)
280 ~ 315	4, 6	5000 小时 (h)

注:

- ¹⁾ 当环境温度每升高 10 °C，润滑脂寿命以及再润滑时间缩短一半。
- ²⁾ 在环境温度 25 度下，40000 小时适用于电动机水平安装，且轴不受额外的轴向力影响；

Note:

- ¹⁾ If the coolant temperature is increased by 10 K, the grease lifetime and regreasing interval are halved.
- ²⁾ 40000 h apply to horizontally installed motors with coupling output without additional axial loads.

电动机轴驱动端允许的最大悬臂力

Permissible cantilever forces on DE shaft

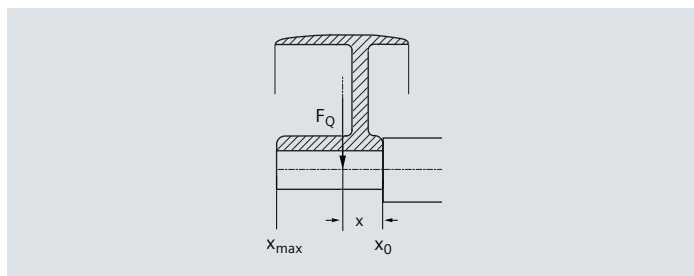

为了计算径向负载的最大悬臂力，据轴肩处的悬臂力 F_Q (N) 必须位于轴伸端以内，（长度为 x ）。长度 x [mm] 是距离轴肩的距离。长度最长为 x_{max} ，与轴伸长度相同。总的悬臂力 F_Q 使用以下公式计算。

$$F_Q = c \cdot F_U$$

预紧力系数 c 是从皮带制造商那得到的经验数值，下面的估算值可以应用。

- 对于一般扁平的皮带， $c = 2$ ；
- 对于 V 型皮带， $c = 2 \sim 2.5$ ；
- 对于特殊的皮带（取决于皮带类型和负载）， $c = 2 \sim 2.5$ 。

计算切向力 F_U (N) 使用下列公式：

$$F_U = 2 \cdot 10^7 \frac{P}{n \times D}$$

- F_U 切向力 (N)
- P 额定功率 (kW)
- n 额定转速
- D 滑轮直径 (mm)

In order to calculate the admissible cantilever forces for a radial load, the line of force (i.e. the centerline of the pulley) of the cantilever force F_Q (N) must lie within the free shaft extension (dimension x). Dimension x [mm] is the distance between the point of application of force F_Q and the shaft shoulder. Dimension x_{max} . Corresponds to the length of the shaft extension. Total cantilever force is calculated using the following equation.

$$F_Q = c \cdot F_U$$

The pre-tension factor c is a value gained from experience from the belt manufacturer. The following approximate value can be assumed.

- For normal flat leather belts with an idler pulley, $c = 2$.
- For v-belts, $c = 2$ to 2.5.
- For special synthetic belts (depending on the type and load), $c = 2$ to 2.5.

The circumferential force F_U (N) is calculated using the following equation.

$$F_U = 2 \cdot 10^7 \frac{P}{n \times D}$$

- F_U circumferential force in N
- P rated motor power (transmitted power) in kW
- n rated motor speed
- D pulleys in mm.

假设电动机不受任何轴向力，下面的表格中列出了允许的径向悬臂力值（单位：牛顿）。

The table below contains the permissible Radial Force values in Newtons with the assumption of zero axial forces.

标准电机最大悬臂力 Admissible cantilever forces for standard version			
机座号 Frame size	极数 Number of poles	悬臂力范围 ¹⁾ Admissible cantilever force ¹⁾	
		for x_0 N	for x_{max} N
80M	2	620	510
	4	790	640
	6	910	740
90S/90L	2	700	560
	4	880	720
	6	1020	820
100L	2	980	790
	4	1230	990
	6	1420	1140
112M	2	980	790
	4	1230	990
	6	1420	1140
132S/132M	2	1440	1120
	4	1230	990
	6	2080	1630
180M 180L	2	1,820	1,470
	4	2,300	1,900
	6	2,630	2,150
200L	2	2,650	2,230
	4	3,350	2,800
	6	3,850	3,230
225S 225M	2	3,000	2,540
	4	3,700	3,000
	6	4,250	3,470
250M	2	3,150	2,620
	4	3,950	3,280
	6	4,600	3,820
280S 280M	2	6,600	5,550
	4	8,300	6,950
	6	9,650	8,120
315S 315M 315L	2	7,100	6,200
	4	8,700	7,250
	6	10,000	8,500

增强悬臂力的轴向设计（编号 L22） Bearing design for increased cantilever forces Order code L22			
机座号 Frame size	极数 Number of poles	悬臂力范围 ¹⁾ Admissible cantilever force ¹⁾	
		for x_0 N	for x_{max} N
80M	2	— ²⁾	— ²⁾
	4	— ²⁾	— ²⁾
	6	— ²⁾	— ²⁾
90S/90L	2	— ²⁾	— ²⁾
	4	— ²⁾	— ²⁾
	6	— ²⁾	— ²⁾
100L	2	1480	1220
	4	1870	1540
	6	2140	1720
112M	2	1480	1220
	4	1870	1540
	6	2140	1720
132S/132M	2	2100	1700
	4	2720	2170
	6	3100	2420
180M 180L	2	3,300	2,700
	4	4,200	3,400
	6	4,750	3,900
200L	2	5,000	4,200
	4	6,330	5,320
	6	7,250	6,080
225S 225M	2	5,650	4,800
	4	6,950	5,600
	6	7,900	6,500
250M	2	6,700	5,600
	4	8,500	7,000
	6	9,500	7,800
280S 280M	2	11,500	9,500
	4	17,000	14,000
	6	20,000	17,000
315S 315M 315L	2	14,600	12,300
	4	20,000	16,500
	6	23,000	19,000

¹⁾ 对于安装型式为 IM B6, IM B7, IM B8, IM V5, IM V6 时，在电机底脚的支撑力足够的情况下，皮带张力垂直于或指向安装平面。采用底脚安装的电动机两个底脚必须牢固。

²⁾ 增强悬臂力型只适用于 FS100 ~ 315

¹⁾ It should be considered that for types of construction IM B6, IM B7, IM B8, IMV5 and IM V6 the belt tension is only permitted to act parallel to the mounting plane or towards the mounting plane and the feet must be supported. Both feet must be secured for foot-mounting types of construction.

²⁾ Reinforced version only from FS100 ~ 315

噪声

噪声值

噪声值根据 DIN EN ISO 1680 标准在噪音室测得。表面声压级噪声 L_{pfa} 计算表示单位为 dB (A)。声压级噪声的空间平均值是在其测量面上测得的。测量面是距离电动机表面一立方米的地方。声功率级噪声用 L_{WA} 来表示，单位为 dB (A)。下面给出噪声值仅适用于电动机在 50 Hz 电源供电空载运行时的情况，容差为 +3 dB。当在 60 Hz 电源下空载运行时，偏差值大约为 +4 dB。

Noise levels

Noise levels for mains-fed operation

The noise levels are measured in accordance with DIN EN ISO 1680 in a dead room. It is specified as the A-valued measuring-surface sound pressure level L_{pfa} in dB (A). This is the spatial mean value of the sound pressure levels measured on the measuring surface. The measuring surface is a cube 1 m away from the motor surface. The sound power level is also specified as L_{WA} in dB (A). The following specified values are only valid for no load at 50 Hz with no load, and the tolerance is +3 dB. While motor operating 60 Hz with no load, the values are approximately +4 dB (A) higher.

机座号	同步转速 synchronous speed (r/min)		
	L_{pfa} / L_{WA} (dB (A))		
	3000 (2 极 poles)	1500 (4 极 poles)	1000 (6 极 poles)
80	51 / 62	45 / 56	44 / 55
90	55 / 67	47 / 59	45 / 57
100	62 / 74	52 / 64	49 / 61
112	65 / 77	53 / 65	53 / 65
132	67 / 79	59 / 71	57 / 69
160	69 / 81	61 / 73	61 / 73
180	70 / 83	63 / 76	59 / 73
200	71 / 84	63 / 76	59 / 73
225	72 / 85	65 / 78	60 / 74
250	75 / 89	66 / 79	62 / 76
280	77 / 91	76 / 80	64 / 78
315	78 / 92	74 / 88	69 / 83

L_{pfa} – 声压级

L_{WA} – 声功率级

L_{pfa} – sound pressure level

L_{WA} – sound power level

振动

所有电动机转子都使用半键按照 A 级（标准）振动等级进行动态平衡。

电动机在空载时测得振动速度有效值不超过下表中的 A 级所列值。

Vibration

The rotors are dynamically balanced to severity grade A using a half key.

Table below contains the effective vibration values for unloaded motors.

振动等级 Vibration grade	机座号 Frame size (mm)	80 ≤ FS ≤ 132	160 ≤ FS ≤ 280	280 < FS ≤ 315
A	安装方式 Mounting	Vibration velocity 振动速度 (mm/s)	Vibration velocity 振动速度 (mm/s)	Vibration velocity 振动速度 (mm/s)
	自由悬置 Free suspension	1.6	2.2	2.8
	刚性安装 Rigid mounting	1.3	1.8	2.3
B	自由悬置 Free suspension	0.7	1.1	1.8
	刚性安装 Rigid mounting	-	0.9	1.5

电气特性

Electrical design

额定输出

SIMOTICS 1LE0003 系列超高效低压电动机的额定功率是指电动机在连续运行的情况下 S1 (IEC 60034-1)，此时周围环境温度为 -20 °C ~ 40 °C，海拔高度不超过 1000 m。

Rated Output

SIMOTICS 1LE0003 premium efficiency low voltage motors' rated output powers means that the motor runs under continuous duty S1 (IEC 60034 - 1) operation when operated at ambient temperature from -20 °C to 40 °C and at altitudes of up to 1000 m over sea.

电压、频率

IEC 60034-1 将电压和频率的偏差分为 A 类 (电压偏差 ±5 %，频率偏差 ±2 %) 和 B 类 (电压偏差 ±10 %，频率偏差 +3 % / -5 %)。电动机均能够在 A 类和 B 类提供额定转矩。在 A 类中，温度比正常运行下温度大约提升 10 K。

Voltage and Frequency

IEC 60034-1 differentiates between Category A (combination of voltage deviation ±5 % and frequency deviation ±2 %) and Category B (combination of voltage deviation ±10 % and frequency deviation +3 % / -5 %) for voltage and frequency fluctuations. The motors can supply their rated torque in both Category A and B. In Category A, the temperature rise is approximately 10 K higher than during normal operation.

标准 Standard	类别 Category	类别 Category
60034 - 1	A	B
电压偏差 Voltage deviation	±5 %	±10 %
频率偏差 Frequency deviation	±2 %	+3 % / -5 %

根据标准，不推荐电动机在 B 类情况下长时间运行
According to the standard, longer operation is not recommended for Category B.

电气数据公差

- 效率 η
 $P_{\text{rated}} \leq 150 \text{ kW}: -0.15 \times (1 - \eta)$
 $P_{\text{rated}} > 150 \text{ kW}: -0.10 \times (1 - \eta)$
 效率 η 为小于 1 的值
- 功率因数: $(1 - \cos \phi) / 6$
 最小绝对值: 0.02
 最大绝对值: 0.07
- 转差率: ±20 % (电动机的偏差 < 1 kW ± 30 % 时是允许的)
- 堵转电流: +20 %
- 堵转转矩: -15 % ~ +25 %
- 最大转矩: -10 %
- 转动惯量: ±10 %

Tolerance for electrical data

- Efficiency η at
 $P_{\text{rated}} \leq 150 \text{ kW}: -0.15 \times (1 - \eta)$
 $P_{\text{rated}} > 150 \text{ kW}: -0.10 \times (1 - \eta)$
 With η being a decimal number
- Power factor - $(1 - \cos \phi) / 6$
 Minimum absolute value: 0.02
 Maximum absolute value: 0.07
- Slip ±20 % (for motors < 1 kW ±30 % is admissible)
- Locked-rotor current +20 %
- Locked-rotor torque -15 % to +25 %
- Breakdown torque -10 %
- Moment of inertia ±10 %

过载倍数

根据 IEC60034 标准要求，1LE0003 系列电动机能够在额定电压和频率下承受 1.5 倍的额定电流达 2 分钟。

Overload times

According to IEC60034, 1LE0003 series motors are designed to withstand overload capacity of 1.5 times rated current for 2 minutes at rated voltage and frequency.

绝缘系统

SIMOTICS 1LE0003 系列超高效低压电动机绝缘系统具有可靠性、耐用性好和寿命长、耐冲击能力强的特点。

SIMOTICS 1LE0003 系列超高效低压电动机标准设计温度等级为 155 (F)。当 1LE0 电动机直接供电，且输出额定功率时，其绝缘系统按 130 (B) 温度等级使用。

电动机保护

电动机过热保护

电动机热保护是指将温度保护传感器或温度检测传感器嵌入电动机定子绕组或其他适当的地方，从而使其不会因为过热而受到破坏。

不同的电动机热保护方式可以在电动机订货号的第 15 位采用不同的字母或者选项号来表示。下面是电动机的绕组保护和轴承保护的几种保护方式。

绕组保护

■ PTC 热敏电阻温度保护

目前，最常用的电动机绕组过热保护方式是采用在电动机绕组中安装 PTC 热敏电阻进行保护。由于热敏电阻的热容量较低以及其在绕组间优良的热传导特性，绕组温度可被准确的监控。当达到极限温度时（标称跳闸温度），PTC 热敏电阻阻值会出现一个阶跃变化。这一变化被跳闸装置捕捉后，即可断开辅助回路。

PTC 热敏电阻本身不能耐受大电流和高电压。否则会导致半导体器件损坏。PTC 热敏电阻和跳闸装置的开关滞后效应小，因此可以实现快速重起。对于重载起动、起动频率高、负载变化大、环境温度高或电源波动大等应用场合，建议电动机使用该保护。

Insulation system

The insulation system of SIMOTICS 1LE0003 premium efficiency low voltage motor results in high reliability, a long service life and high resistance to stress, for example, during starting or under overload conditions.

SIMOTICS 1LE0003 premium efficiency low voltage motor is designed for temperature class 155 (F). At rated output with line-fed operation, the motors can be used in temperature class 130 (B).

Motor protection

Motor thermal overload protection

Motor thermal protection means to use of thermal protectors and thermal detectors incorporated into the stator windings or placed in other suitable positions in motor in order to protect them against serious damage due to thermal overloads.

The order variants for motor protection are coded with letters in the 15th position of the Motor Order No., or ordered with Option code. Some protection method about winding protection and bearing protection are shown in the following.

Winding protection

■ PTC thermistors protection

The most comprehensive protection against thermal overloading of the motor is provided by PTC thermistors (thermistor motor protection) installed in the motor winding. The temperature of the winding can be accurately monitored thanks to its low heating capacity and the excellent heat contact with the winding. When a limit temperature is reached (nominal tripping temperature), the resistance of PTC thermistors will have a step change. This is evaluated by a tripping unit and can be used to open auxiliary circuits.

The PTC thermistors themselves cannot be subjected to high currents and voltages. This would result in destruction of the semiconductor. The switching hysteresis of the PTC thermistor and tripping unit is low, which supports fast restarting of the drive. Motors with this type of protection are recommended for heavy duty starting, switching duty, extreme changes in load, high ambient temperatures or fluctuating supply systems.

PTC 曲线图
The graph of PTC

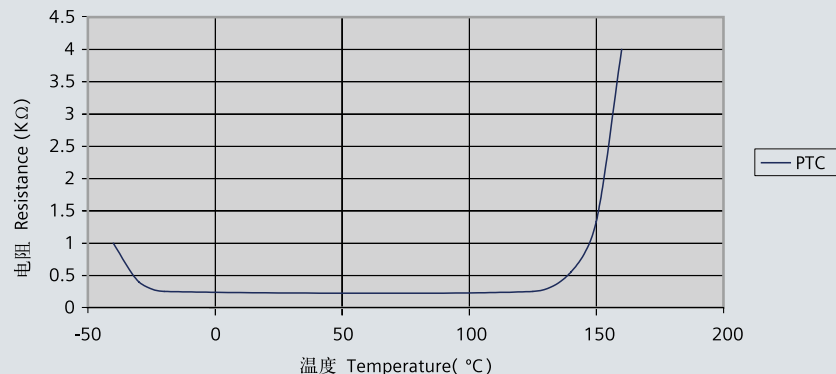

两种 PTC 热敏电阻温度保护

- 电动机绕组带一组三芯串联的 PTC 热敏电阻用于跳闸，跳闸温度为 155 °C，电动机订货号第 15 位字母为“B”，需 2 个辅助接线端子。
- 电动机绕组带两组三芯串联的 PTC 热敏电阻，其中一组用于在电动机跳闸前报警，一组用于跳闸，报警温度为 145 °C，跳闸温度为 155 °C，电动机订货号第 15 位字母为“C”，需 4 个辅助接线端子。

■ KTY84-130 温度传感器温度保护

当电动机变频应用时，推荐使用 KTY84-30 温度传感器进行绕组保护。KTY84-130 温度传感器特性曲线如下所示。

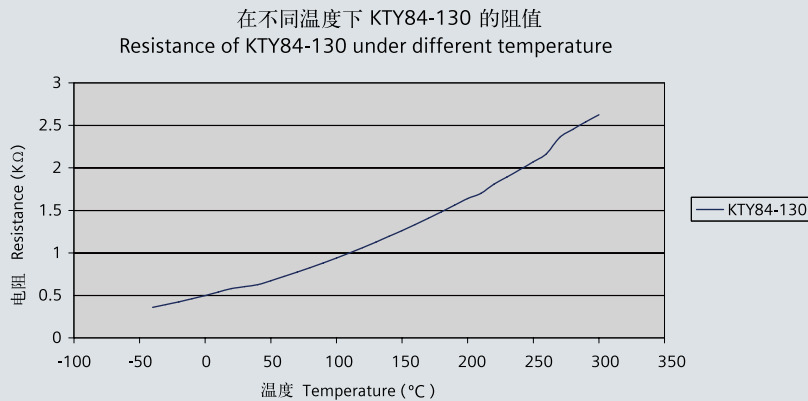

一些西门子变频器可以通过温度传感器的电阻来确定电动机的温度，从而设定电动机报警和跳闸的温度。

电动机绕组带一个 KTY 84-130 温度传感器，订货号第 15 位字母为“F”，需 2 个辅助接线端子。

■ PT100 热敏电阻传感器温度保护

PT100 热敏电阻是一种精确高、灵敏度高的传感器，其线性温度阻值优于其他电阻式传感器，性能稳定、可靠性高，其特性曲线如下。

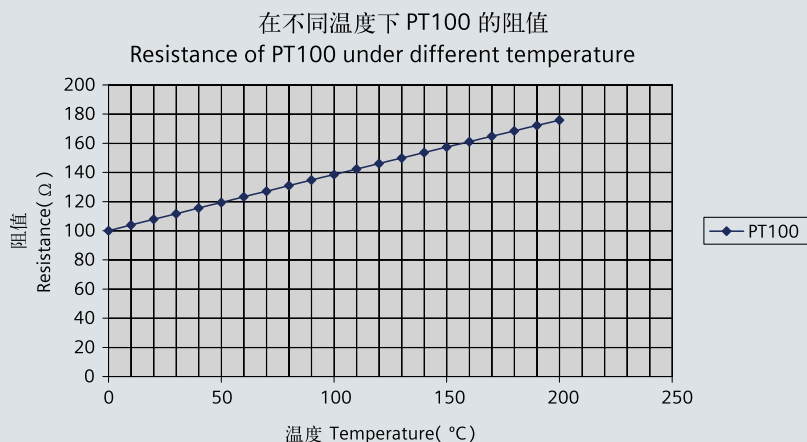

2 alternatives of PTC protection

- Motor winding is protected with PTC thermistors with 3 embedded temperature sensors for tripping. Connection be done through 2 auxiliary terminals in the connection box. 15th position of Motor Order No. letter B.
- Motor winding is protected with two sets of three temperature sensors, one set is for warning, another set for tripping. The warning temperature is 145 °C, and tripping temperature is 155 °C. Connection be done through 4 auxiliary terminals in the connection box. 15th position of Motor Order No. letter C.

■ KTY84-130 temperature sensor protection

When motor with converter fed operation, KTY84-30 is recommended to be configured for winding protection. The following chart show the characteristic of KTY84-30.

Some converters from Siemens determine the motor temperature using the resistance of the temperature sensor. They can be set to a required temperature for alarm and tripping.

Motor winding with embedded temperature detector sensor KTY 84 -130. Two auxiliary terminals are provided in the connection box. 15th position of Motor Order No. letter F.

■ PT100 resistance thermometers protection

PT100 thermometers are a high precision, high sensitivity, better linear temperature resistance, more stable performance, and high reliability sensor, whose characteristics are as following.

两种 PT100 热敏电阻温度保护

- 电动机绕组带 3 个 2 线制 PT100 测温元件，电动机订货号第 15 位字母为“H”，需 6 个辅助接线端子。
- 电动机绕组带 6 个 2 线制 PT100 测温元件，电动机订货号第 15 位字母为“J”，需 12 个辅助接线端子。

轴承保护

电动机轴承标配不带任何保护。对于某些苛刻的应用，推荐对轴承采取保护措施。轴承保护是通过在电动机驱动端和非驱动端的轴承端盖拧入温度传感器来进行保护。温度传感器的引接线引入电动机主接线盒内。

电动机轴承装两个 PT100 测温元件，选件号为 Q5A，需 4 个辅助接线端子。

防潮加热保护

当电动机处于较为恶劣的环境时，比如湿度非常大或者昼夜温差比较大，电动机的绕组很可能出现凝露的现象，这样会带来电动机烧毁的风险。对于这种情况，建议对电动机绕组配置防潮加热带（选件号：Q04）进行保护。

电动机防潮加热带必须在电动机工作过程中处于不工作状态；当电动机停机时，防潮加热带必须启动工作，为绕组加热。防潮加热带的电气参数如下表所示。

防潮加热带电气参数

机座号 Frame size	功率 Power (W)	电压 Voltage
80 ~ 90	20	220 V
100 ~ 112	30	220 V
132 ~ 160	40	220 V
180 ~ 200	50	220 V
225 ~ 280	60	220 V
315	80	220 V

2 alternatives of PT100

- Installation of 3 PT100 resistance thermometers. Connection be done through 6 auxiliary terminals in the connection box. 15th position of Motor Order No. letter H.
- Installation of 6 PT100 resistance thermometers. Connection be done through 12 auxiliary terminals in the connection box. 15th position of Motor Order No. letter J.

Bearing protection

Motors bearing has no protection as standard. For some severe application, such as high load, high coolant temperature and etc., the bearing is recommended to be protected. The bearing is protected through thermometers screwed into the bearing plates of motor driven end (DE) and non-drive-end (NDE). The wires are routed through the main connection box.

Installation of 2 PT100 screwed-in resistance thermometers for motor bearings, Option code: Q5A. Connection be done through 4 auxiliary terminals in the connection box.

Anti-condensation heater

Motors whose windings are at risk of condensation due to the climatic conditions, e.g. inactive motors in humid atmospheres or motors that are subjected to widely fluctuating temperatures can be equipped with anti-condensation heaters (Option code: Q04).

Anti-condensation heaters must be switched off during operation. When motor shut down, the heaters must be switched on.

Electrical data of Anti-condensation heater

变频应用

SIMOTICS 1LE0003 系列超高效低压电动机适于变转速、恒转速的各种应用，如风机、泵、压缩机、纺织机械等。

当变频器驱动电动机时，电磁干扰的程度大小取决于变频器的类型（种类，IGBT 数量，干扰控制措施及制造商）、布线、距离以及应用需求。在设计 and 应用阶段必须参考变频器制造商关于电磁兼容性的安装指导。

当电动机变频应用（变频器供电），且输出额定功率时，电动机的使用温度等级为 155 (F)。为了避免杂散电流对电动机轴承的损坏，推荐 FS250 ~ 315 电动机使用绝缘轴承。请向西门子咨询关于绝缘轴承的详细信息。

变频器驱动运行

SIMOTICS 1LE0003 系列超高效低压电动机的标准绝缘系统设计要求，能够保证其在变频器供电电压不超过 460 V 时正常运行。

该系列电动机变频器驱动时，其负载扭矩特性如以下图表所示：

Converter fed application

SIMOTICS 1LE0003 low voltage motors are suitable for pumps, fans, compressors, textile machine and mechanical machine applications where variable or constant speed is required.

In application where the motor is driven by a converter, the degree of electrical interference depends on the type of converter used (type, number of IGBTs, interference suppression measures, and manufacturer), cabling, distance and application requirements. The installation guidelines of the converter manufacturer with regards to electromagnetic compatibility must be considered at all times during the design and implementation phases.

At rated output with converter fed operation, the motors will be used in temperature class 155 (F). To prevent damage as a result of bearing currents, insulated bearings are recommended to be assembled for FS250 ~ 315. Please inquire Siemens about the detailed information of insulated bearing.

Converter-fed operation

The standard insulation of SIMOTICS 1LE0003 low voltage motors is designed such that operation is possible on the converter at mains voltage up to 460 V.

The load torque characteristics of this series motor is referred in the following diagram:

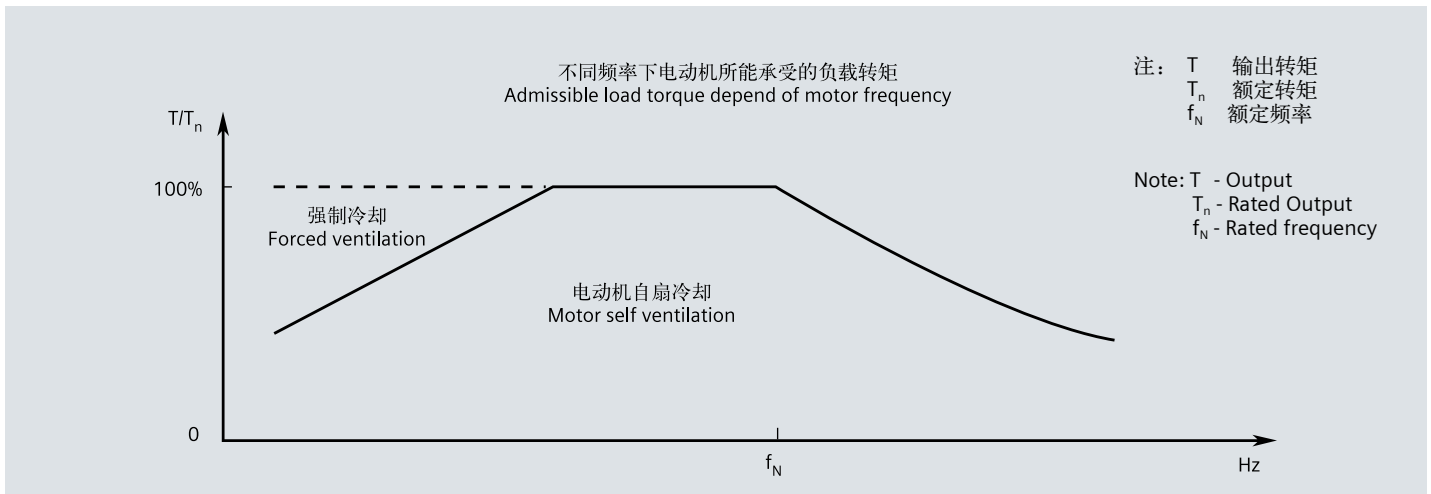

当负载转矩在允许的转矩范围内时，电动机能够自扇冷却；当负载转矩超过所允许的转矩时，电动机需要强迫冷却。

在电动机运行速度超过额定转速时，噪声和振动值将增加，并且轴承的寿命将缩短。需要注意再润滑周期和润滑脂的寿命。

变频运行时当频率超过 60 Hz 时，必需按照特定的限值进行动平衡。

By usage with admissible torque and below, the motor can be operated with self cooling; by usage over the admissible torque line, the motor with forced ventilation is needed.

At operating speeds above rated speed the noise and vibration levels increase and the bearing life time reduce. Attention should be paid to the re-greasing intervals and the grease service life.

For converter-fed operation with frequencies greater than 60 Hz special balancing is required for compliance with the specified limit values.

最大安全转速如下表

The allowed maximum safe operating speed is shown in the diagram

机座号 Frame Size	2 极 2 pole		4 极 4 pole		6 极 6 pole	
	最高转速 Max. rpm	最大频率 fmax	最高转速 Max. rpm	最大频率 fmax	最高转速 Max. rpm	最大频率 fmax
80	5200	87	3600	120	2400	120
90	5200	87	3600	120	2400	120
100	5200	87	3600	120	2400	120
112	5200	87	3600	120	2400	120
132	4500	75	2700	90	2400	120
160	4500	75	2700	90	2400	120
180	4500	75	2700	90	2400	120
200	4500	75	2300	77	1800	90
225	3600	60	2300	77	1800	90
250	3600	60	2300	77	1800	90
280	3600	60	2300	77	1800	90
315	3600	60	2300	77	1800	90

电压承受值

绕组绝缘的电介质应力决定于：

- 电压峰值，上升时间以及变频器产生的脉冲频率；
变频器与电动机连接电缆的特性和长度；
- 绕组结构和其他系统参数，尤其是绝缘系统中不同绕组的对地电压（代表了绝缘系统的电介质应力）。

图表所示为 1LE0003 电动机标准绝缘能承受电压的峰值和上升时间：

Voltage withstand levels

The dielectric stress of the winding insulation is determined by:

- the peak voltage, rise time and frequency of the impulses produced by the converter.
- the characteristics and the length of the connection leads between the converter and motor.
- the winding construction and other system parameters, especially the voltages between the different parts of the winding and the ground represent dielectric stress at the insulation system.

The standard insulation of the 1LE0003 motors is designed to withstand voltage peak and rise time which is showed in the diagram:

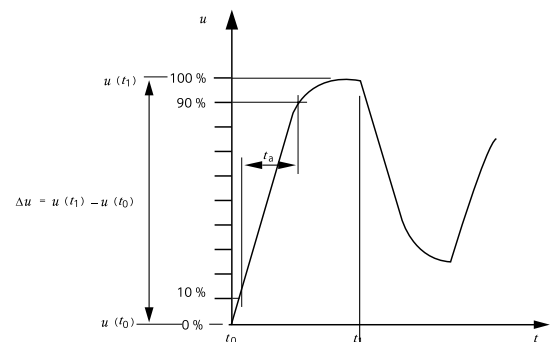
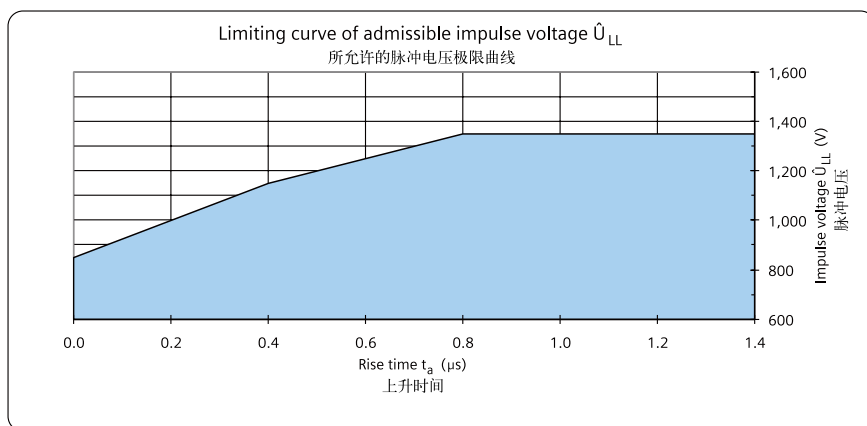

数值参照 IEC 60034-17, GB/T 20161-2008 标准。

The values refer to standard IEC 60034-17 and GB/T 20161-2008.

型号与订货号

Motor Type and Order No.

电动机型号 Motor Type

1	2	3	4	5	6	7	8
0	C	V	3				

电动机订货号 Order No.

1	2	3	4	5	6	7	-	8	9	10	11	12	-	13	14	15	16
1	L	E	0	0	0	3	-										

铸铁壳系列全封闭通风冷却电动机
Cast iron TEFC motor

中国能效等级 2 级, IE3 效率等级
China energy efficiency grade 2, IE3 efficiency

机座号 Frame size
08=80; 09=90; 10=100; 11=112; 13=132; 16=160
18=180; 20=200; 22=225; 25=250; 28=280; 31=315

铁心长 Core length
0 or 1 = S; 2 or 3 = M; 4, 5, 6 or 7 = L

极数 Poles
A = 2; B = 4; C = 6

中国能效等级 2 级, IE3 效率等级
China energy efficiency grade 2, IE3 efficiency

机座号 Frame size
0D = 080; 0E = 090; 1A = 100; 1B = 112; 1C = 132; 1D = 160; 1E = 180
2A = 200; 2B = 225; 2C = 250; 2D = 280; 3A = 315

极数 Poles
A = 2; B = 4; C = 6

铁心长度 Core length
0 or 1 = S (短铁心 short); 2 or 3 = M (中铁心 medium); 4 or 5 or 6 or 7 = L (长铁心 long)

电压, 连接方式和频率 Voltage, connections and frequency
21 = 220VD/380VY 50Hz 34 = 400VD/690VY 50Hz 35 = 415VD 50Hz
33 = 380VD/660VY 50Hz 04 = 400VD 50Hz 90¹⁾ = 特殊电压与频率 special voltage & frequency
22 = 230VD/400VY 50Hz 23 = 240VD/415VY 50Hz

结构和安装方式 Construction and mounting type

A²⁾ 3) = IM B3; T³⁾ = IM B6; U³⁾ = IM B7; V³⁾ = IM B8; C³⁾ 8) = IM V5; D³⁾ = IM V6

F³⁾ 4) 6) = IM B5; G³⁾ 6) 8) = IM V1; H³⁾ 6) = IM V3

J³⁾ IM B35; W³⁾ 8) = IM V15; Y³⁾ = IM V35

K³⁾ 5) 6) 7) = IM B14; M³⁾ 6) 7) 8) = IM V18; L³⁾ 6) 7) = IM V19; N³⁾ 7) = IM B34

绕组保护 Winding protection

A = 无绕组保护 without winding protection

B = 绕组带一组三芯串联的 PTC 热敏电阻用于跳闸 3 PTC thermistors for tripping

C = 绕组带两组三芯串联的 PTC 热敏电阻用于报警和跳闸 6 PTC thermistors for alarm and tripping

F = 绕组带一个 KTY 84-130 温度传感器 1 temperature sensor KTY 84-130

H = 绕组带 3 个 Pt100 测温元件 3 resistance thermometers Pt100

J = 绕组带 6 个 Pt100 测温元件 6 resistance thermometers Pt100

接线盒位置 (从驱动端看) Connection box location (view from drive end)

4 = 置顶 on top; 5 = 右侧 on RHS; 6 = 左侧 on LHS

订货号

Order No.

附注:

- 1) 用电压编号 90 及相应选件号来定制其它电压 (参见选项描述) ;
- 2) 当电动机不要求带冷凝水排放孔 (订货号: H03) 时, IM B3 安装结构型式也可适用于 IM B6/7/8、以及不带防护罩的 IM V5/6 安装结构型式的电动机 (FS80 ~ 225), 但电动机铭牌上只标示 IM B3 安装结构型式, 不标示其他安装结构型式;
- 3) 铭牌上标有结构型式。若需要冷凝水排放孔 (订货号: H03), 则必须指明电机的安装结构型式, 以便在制造过程中确定冷凝水排放孔的具体位置。
- 4) 当电动机不要求带冷凝水排放孔 (订货号: H03) 时, IM B5 安装结构型式也可适用于不带防护罩的 IM V1 和 IM V3 安装型式的电动机 (FS80 ~ 225), 但电动机铭牌上只标示 IM B5 安装结构型式, 不标示其他安装结构型式;
- 5) 当电动机不要求带冷凝水排放孔 (订货号: H03) 时, IM B14 安装结构型式也可适用于不带防护罩的 IM V18 和 IM V19 安装结构型式, 但电动机铭牌上只标示 IM B14 安装型式, 不标示其他安装结构型式;
- 6) 对于 IM B5、IM V1、IM V3、IM B14、IM V18 和 IM V19 安装结构型式电动机, 须指定电动机订货号第 16 位数字为“4”;
- 7) 只针对 FS80 ~ 160;
- 8) 电动机标配无防雨罩, 但如需要加带防雨罩用于防护时, 须订购选件号 H00;
- 9) FS80 ~ 132 进线孔的方向朝向非驱动端;

订货号样例:

三相低压交流电动机
4- 极, 15 kW, IM B5, 380VD/660VY 50 Hz, IP55, 接线盒位置处于顶端, 进线孔右侧 (从驱动端看), 带独立驱动风扇。

电动机订货号: 1LE0003-1DB43-3FA4-Z F70

电动机订货号解释

Foot note:

- 1) Order other voltages with voltage code 90 and the corresponding Option code (see under "Option") .
- 2) The types of construction IM B6/7/8, IM V6 and IM V5 without protective cover are also possible as long as no condensation drainage holes (Order code: H03) and no stamping of these types of construction on the rating plate are required. As standard, the type of construction IM B3 is then stamped on the rating plate.
- 3) The type of construction is stamped on the rating plate. When ordering with condensation drainage holes (order code H03), it is absolutely necessary to specify the type of construction for the exact position of the condensation drainage holes during manufacture.
- 4) The types of construction IM V1 and IM V3 without protective cover are also possible as long as no condensation drainage holes (Order code: H03) and no stamping of these types of construction on the rating plate are required. As standard, the type of construction IM B5 is then stamped on the rating plate.
- 5) The types of construction IM V19 and IM V18 without protective cover are also possible as long as no condensation drainage holes (Order code: H03) and no stamping of these types of construction on the rating plate are required. As standard, the type of construction IM B14 is then stamped on the rating plate.
- 6) For motor with IM B5, IM V1, IM V3, IM B14, IM V18 and IM V19 construction and mounting type, the 16th digit of motor order No. must be "4";
- 7) Only for FS80 ~ 160.
- 8) Without canopy, for protective cover with canopy needed Option code H00.
- 9) Cable entry on connection box towards the non-drive.

Order No. example:

Low voltage three phase motor
4-pole, 15 kW, IM B5, 380VD/660VY 50 Hz, IP55, connection box on top and cable entry at right side (view from DE), with separately driven fan.

Motor order code: 1LE0003-1DB43-3FA4-Z F70

Motor order code introduction

1	L	E	0	0	0	3	-	1	D	B	4	3	-	3	F	A	4	-	Z	F	7	0
---	---	---	---	---	---	---	---	---	---	---	---	---	---	---	---	---	---	---	---	---	---	---

超高效电动机 Premium efficiency motor

机座号 Frame size: 160

极数 Poles: 4

机座长度 Frame length: 长机座 (L)

电压, 连接方式和频率 voltage, connection method and frequency: 380VD/660VY 50Hz

结构形式 Construction: IM B5

绕组保护 winding protection: 无 None

接线盒位置 Connection box position: 置顶 On top

其他技术要求 Other technical requirements: 独立驱动风扇 Separately driven fan

选型技术数据表 Technical data table

机座号 Frame Size	电动机型号 Motors Type	订货号 Order No.	额定功率 Rated Output	额定转速 Rated Speed	效率 Efficiency at (50HZ) 4/4 load	效率 Efficiency at (50HZ) 3/4 load	功率因数 Power factor	额定电流 Rated current	
			kW	r/m	%	%		A	
3000rpm 2- pole 220VD/380VY 50HZ									
80M	OCV3082A	1LE0003-0DA22-1 □□□	0.75	2835	80.7	82.9	0.86	1.64	
80M	OCV3083A	1LE0003-0DA32-1 □□□	1.1	2870	82.7	84.0	0.83	2.45	
90S	OCV3090A	1LE0003-0EA02-1 □□□	1.5	2900	84.2	84.8	0.86	3.15	
90L	OCV3094A	1LE0003-0EA42-1 □□□	2.2	2910	85.9	87.2	0.88	4.40	
100L	OCV3104A	1LE0003-1AA42-1 □□□	3	2875	87.1	88.3	0.87	6.0	
3000rpm 2- pole 380VD/660VY 50HZ									
112M	OCV3112A	1LE0003-1BA23-3 □□□	4	2925	88.1	89.6	0.90	7.7	
132S	OCV3130A	1LE0003-1CA03-3 □□□	5.5	2930	89.2	90.2	0.89	10.5	
132S	OCV3131A	1LE0003-1CA13-3 □□□	7.5	2925	90.1	91.5	0.90	14.1	
160M	OCV3162A	1LE0003-1DA23-3 □□□	11	2935	91.2	92.0	0.89	20.5	
160M	OCV3163A	1LE0003-1DA33-3 □□□	15	2930	91.9	92.6	0.89	28.0	
160L	OCV3164A	1LE0003-1DA43-3 □□□	18.5	2940	92.4	93.0	0.89	34.0	
180M	OCV3182A	1LE0003-1EA23-3 □□□	22	2950	92.7	93.0	0.89	40.5	
200L	OCV3204A	1LE0003-2AA43-3 □□□	30	2955	93.3	93.4	0.89	55	
200L	OCV3205A	1LE0003-2AA53-3 □□□	37	2955	93.7	93.9	0.89	67	
225M	OCV3222A	1LE0003-2BA23-3 □□□	45	2960	94.0	94.3	0.89	82	
250M	OCV3252A	1LE0003-2CA23-3 □□□	55	2975	94.3	94.1	0.89	100	
280S	OCV3280A	1LE0003-2DA03-3 □□□	75	2975	94.7	94.8	0.89	135	
280M	OCV3282A	1LE0003-2DA23-3 □□□	90	2975	95.0	95.3	0.90	160	
315S	OCV3310A	1LE0003-3AA03-3 □□□	110	2975	95.2	95.1	0.90	195	
315M	OCV3312A	1LE0003-3AA23-3 □□□	132	2980	95.4	95.3	0.90	235	
315L	OCV3315A	1LE0003-3AA53-3 □□□	160	2978	95.6	95.7	0.91	280	
315L	OCV3316A	1LE0003-3AA63-3 □□□	185	2978	95.7	95.9	0.92	320	
315L	OCV3317A	1LE0003-3AA73-3 □□□	200	2982	95.8	95.9	0.92	345	
1500rpm 4-pole 220VD/380VY 50HZ									
80M	OCV3082B	1LE0003-0DB22-1 □□□	0.55	1440	80.8	81.8	0.76	1.36	
80M	OCV3083B	1LE0003-0DB32-1 □□□	0.75	1445	82.5	82.9	0.75	1.84	
90S	OCV3090B	1LE0003-0EB02-1 □□□	1.1	1430	84.1	85.1	0.79	2.50	
90L	OCV3094B	1LE0003-0EB42-1 □□□	1.5	1440	85.3	86.0	0.79	3.40	
100L	OCV3102B	1LE0003-1AB42-1 □□□	2.2	1445	86.7	87.1	0.82	4.70	
100L	OCV3105B	1LE0003-1AB52-1 □□□	3	1450	87.7	88.1	0.82	6.3	
1500rpm 4-pole 380VD/660VY 50HZ									
112M	OCV3112B	1LE0003-1BB23-3 □□□	4	1450	88.6	89.6	0.82	8.4	
132S	OCV3130B	1LE0003-1CB03-3 □□□	5.5	1455	89.6	90.9	0.84	11.1	
132M	OCV3132B	1LE0003-1CB23-3 □□□	7.5	1455	90.4	91.7	0.85	14.8	
160M	OCV3162B	1LE0003-1DB23-3 □□□	11	1460	91.4	92.4	0.86	21.5	
160L	OCV3164B	1LE0003-1DB43-3 □□□	15	1460	92.1	92.9	0.86	29.0	
180M	OCV3182B	1LE0003-1EB23-3 □□□	18.5	1470	92.6	93.0	0.83	36.5	
180L	OCV3184B	1LE0003-1EB43-3 □□□	22	1470	93.0	93.7	0.83	43.5	

	额定转矩 Rated torque	起动电流 Starting Current	起动转矩 Starting torque	最大转矩 Max torque	转动惯量 Moment of inertia (J) (EFF2)	重量 Weight IMB3
	Nm				kgm ²	kg
3000rpm 2- pole 220VD/380VY 50HZ						
	2.5	6.0	2.4	3.0	0.00208	16.0
	3.7	6.5	2.4	3.4	0.00154	18.0
	4.9	6.5	2.0	3.4	0.00276	24
	7.2	7.5	2.3	3.6	0.00356	28
	10.0	7.8	2.6	3.6	0.00462	39
3000rpm 2- pole 380VD/660VY 50HZ						
	13.1	7.8	2.6	3.6	0.0088	46
	17.9	7.5	2.3	3.6	0.0185	64
	24.5	7.5	2.3	3.6	0.0232	71
	35.8	7.5	2.3	2.5	0.0390	99
	48.9	7.5	2.4	3.4	0.0472	107
	60.1	7.8	2.4	3.4	0.0577	131
	71.2	7.8	2.4	3.4	0.077	171
	97.0	7.8	2.4	3.4	0.133	250
	120	7.8	2.4	3.4	0.152	260
	145	7.8	2.4	3.2	0.254	342
	177	7.8	2.4	3.2	0.443	425
	241	7.2	2.4	3.0	0.780	545
	289	7.2	2.4	3.4	0.950	620
	353	7.2	1.8	2.6	1.300	790
	423	7.9	2.1	2.6	1.510	960
	513	7.6	2.1	2.6	1.810	1060
	593	7.6	2.3	2.6	2.190	1145
	641	7.9	2.6	3.2	2.190	1165
1500rpm 4-pole 220VD/380VY 50HZ						
	3.6	5.5	2.2	3.2	0.00216	16.5
	5.0	6.0	2.7	3.7	0.00250	18.0
	7.3	6.5	2.7	3.7	0.00389	24
	9.9	6.5	2.7	3.8	0.00499	27
	14.5	8.3	3.7	4.6	0.01125	42
	19.8	8.3	3.7	4.6	0.01313	46
1500rpm 4-pole 380VD/660VY 50HZ						
	26.3	8.3	3.7	4.6	0.0149	52
	36.1	7.8	2.4	3.8	0.0285	71
	49.2	7.8	2.4	3.8	0.0356	83
	72.0	7.8	2.4	3.8	0.0648	110
	98.1	7.8	2.6	3.8	0.0811	134
	120	7.8	2.6	3.6	0.126	170
	143	7.8	2.6	3.6	0.146	192

选型技术数据表 Technical data table

机座号 Frame Size	电动机型号 Motors Type	订货号 Order No.	额定功率 Rated Output	额定转速 Rated Speed	效率 Efficiency at (50HZ) 4/4 load	效率 Efficiency at (50HZ) 3/4 load	功率因数 Power factor	额定电流 Rated current
			kW	r/m	%	%	A	
1500rpm 4-pole 380VD/660VY 50HZ								
200L	OCV3204B	1LE0003-2AB43-3 □□□	30	1470	93.6	94.3	0.84	58
225S	OCV3220B	1LE0003-2BB03-3 □□□	37	1478	93.9	94.1	0.85	70
225M	OCV3222B	1LE0003-2BB23-3 □□□	45	1478	94.2	94.2	0.85	85
250M	OCV3252B	1LE0003-2CB23-3 □□□	55	1482	94.6	95.0	0.86	103
280S	OCV3280B	1LE0003-2DB03-3 □□□	75	1485	95.0	95.3	0.86	139
280M	OCV3282B	1LE0003-2DB23-3 □□□	90	1485	95.2	95.6	0.87	165
315S	OCV3310B	1LE0003-3AB03-3 □□□	110	1488	95.4	95.7	0.87	200
315M	OCV3312B	1LE0003-3AB23-3 □□□	132	1488	95.6	95.9	0.87	240
315L	OCV3315B	1LE0003-3AB53-3 □□□	160	1488	95.8	96.1	0.87	290
315L	OCV3316B	1LE0003-3AB63-3 □□□	185	1488	95.9	96.2	0.87	335
315L	OCV3317B	1LE0003-3AB73-3 □□□	200	1490	96.0	96.3	0.88	360
1000rpm 6-pole 220VD/380VY 50HZ								
80M	OCV3083C	1LE0003-0DC32-1 □□□	0.55	935	77.2	77.5	0.67	1.62
90S	OCV3090C	1LE0003-0EC02-1 □□□	0.75	940	78.9	80.3	0.70	2.05
90L	OCV3094C	1LE0003-0EC42-1 □□□	1.1	945	81.0	81.6	0.69	3.00
100L	OCV3104C	1LE0003-1AC42-1 □□□	1.5	945	82.5	84.1	0.74	3.75
112M	OCV3112C	1LE0003-1BC22-1 □□□	2.2	945	84.3	86.1	0.74	5.4
132S	OCV3130C	1LE0003-1CC02-1 □□□	3	965	85.6	86.6	0.75	7.1
1000rpm 6-pole 380VD/660VY 50HZ								
132M	OCV3132C	1LE0003-1CC23-3 □□□	4	955	86.8	88.5	0.75	9.3
132M	OCV3133C	1LE0003-1CC33-3 □□□	5.5	960	88.0	89.2	0.76	12.5
160M	OCV3162C	1LE0003-1DC23- □□□	7.5	965	89.1	90.4	0.78	16.4
160L	OCV3164C	1LE0003-1DC43-3 □□□	11	970	90.3	90.3	0.77	23.5
180L	OCV3184C	1LE0003-1EC43-3 □□□	15	975	91.2	92.1	0.80	31.0
200L	OCV3204C	1LE0003-2AC43-3 □□□	18.5	978	91.7	92.5	0.80	38.5
200L	OCV3205C	1LE0003-2AC53-3 □□□	22	978	92.2	93.1	0.80	45.5
225M	OCV3222C	1LE0003-2BC23-3 □□□	30	982	92.9	93.9	0.84	58
250M	OCV3252C	1LE0003-2CC23-3 □□□	37	985	93.3	94.1	0.84	72
280S	OCV3280C	1LE0003-2DC03-3 □□□	45	985	93.7	94.5	0.84	87
280M	OCV3282C	1LE0003-2DC23-3 □□□	55	988	94.1	94.6	0.84	106
315S	OCV3310C	1LE0003-3AC03-3 □□□	75	990	94.6	95.0	0.84	143
315M	OCV3312C	1LE0003-3AC23-3 □□□	90	990	94.9	95.3	0.84	172
315L	OCV3315C	1LE0003-3AC53-3 □□□	110	991	95.1	95.3	0.85	205
315L	OCV3316C	1LE0003-3AC63-3 □□□	132	991	95.4	95.7	0.85	245

	额定转矩 Rated torque	起动电流 Starting Current	起动转矩 Starting torque	最大转矩 Max torque	转动惯量 Moment of inertia (J) (EFF2)	重量 Weight IMB3
	Nm				kgm ²	kg
1500rpm 4-pole 380VD/660VY 50HZ						
195	7.8	7.8	2.6	3.6	0.220	255
239	8.3	8.3	3.3	3.6	0.461	315
291	8.3	8.3	3.3	3.6	0.479	342
354	7.6	7.6	2.6	3.3	0.820	440
482	7.6	7.6	2.6	3.0	1.310	580
579	7.6	7.6	2.6	3.0	1.690	685
706	7.9	7.9	3.3	3.0	2.770	800
847	7.9	7.9	3.3	3.0	3.000	1035
1027	7.9	7.9	3.3	3.0	3.140	1065
1187	7.9	7.9	3.3	3.0	3.460	1115
1282	7.9	7.9	3.3	3.0	3.790	1175
1000rpm 6-pole 220VD/380VY 50HZ						
5.6	5.0	5.0	2.7	3.4	0.00310	19.5
7.6	5.0	5.0	2.4	3.2	0.00436	25
11.1	5.5	5.5	2.7	3.5	0.00513	28
15.2	5.5	5.5	2.7	3.5	0.01136	42
22.2	6.0	6.0	2.7	3.4	0.01451	50
29.7	6.0	6.0	2.7	4.0	0.02666	67
1000rpm 6-pole 380VD/660VY 50HZ						
40.0	6.0	6.0	2.3	3.4	0.0305	76
54.7	6.5	6.5	2.3	4.0	0.0413	88
74.2	6.5	6.5	2.3	3.6	0.0703	112
108	7.0	7.0	2.3	3.6	0.0707	144
147	7.0	7.0	2.3	3.0	0.185	175
181	7.0	7.0	2.3	3.0	0.284	235
215	7.0	7.0	2.4	3.0	0.327	251
292	7.6	7.6	2.4	3.0	0.710	350
359	7.6	7.6	2.4	3.0	1.030	430
436	7.8	7.8	3.0	3.0	1.400	520
532	7.8	7.8	3.0	3.0	1.700	585
723	7.8	7.8	2.6	3.0	2.730	790
868	7.8	7.8	2.6	3.0	3.290	950
1060	7.8	7.8	2.6	3.0	4.170	1085
1272	7.8	7.8	2.6	3.0	4.490	1135

选件 Options

电动机订货号 Motor order code	选件号 Option Code ¹⁾	描述 Description	应用范围 Application Scope
电压与频率 Voltages and frequency			
1LE0003- □□□□ 2-1 □□□□		220VD / 380VY 50 Hz (0.55 kW ~ 3 kW ²⁾)	FS80 ~ 315
1LE0003- □□□□ 3-3 □□□□		380VD / 660VY 50 Hz (4 kW ~ 315 kW ²⁾)	FS80 ~ 315
1LE0003- □□□□ 2-2 □□□□		230VD / 400VY 50 Hz	FS80 ~ 315
1LE0003- □□□□ 3-4 □□□□		400VD / 690VY 50 Hz	FS80 ~ 315
1LE0003- □□□□ 2-3 □□□□		240VD / 415VY 50 Hz	FS80 ~ 315
1LE0003- □□□□ 0-4 □□□□		400VD 50 Hz	FS80 ~ 315
1LE0003- □□□□ 3-5 □□□□		415VD 50 Hz	FS80 ~ 315
1LE0003- □□□□ 9-0 □□□□ -Z	M1A	220VD / 380VY 60 Hz (60 Hz output, 60 Hz 输出)	FS80 ~ 315
1LE0003- □□□□ 9-0 □□□□ -Z	M1B	380VD / 660VY 60 Hz (60 Hz output, 60 Hz 输出)	FS80 ~ 315
1LE0003- □□□□ 9-0 □□□□ -Z	M1C	440VY 60Hz (60Hz output, 60Hz 输出)	FS80 ~ 315
1LE0003- □□□□ 9-0 □□□□ -Z	M1D	440VD 60Hz (60Hz output, 60Hz 输出)	FS80 ~ 315
1LE0003- □□□□ 9-0 □□□□ -Z	M1E	460VY 60 Hz (60 Hz output, 60 Hz 输出)	FS80 ~ 315
1LE0003- □□□□ 9-0 □□□□ -Z	M1F	460VD 60 Hz (60 Hz output, 60 Hz 输出)	FS80 ~ 315
1LE0003- □□□□ 9-0 □□□□ -Z	M2A	220VD/380VY 60Hz (50Hz output, 50Hz 功率输出)	FS80 ~ 315
1LE0003- □□□□ 9-0 □□□□ -Z	M2B	380VD/660VY 60Hz (50Hz output, 50Hz 功率输出)	FS80 ~ 315
1LE0003- □□□□ 9-0 □□□□ -Z	M2C	440VY 60Hz (50Hz output, 50Hz 功率输出)	FS80 ~ 315
1LE0003- □□□□ 9-0 □□□□ -Z	M2D	440VD 60Hz (50Hz output, 50Hz 功率输出)	FS80 ~ 315
1LE0003- □□□□ 9-0 □□□□ -Z	M2E	460VY 60Hz (50Hz output, 50Hz 功率输出)	FS80 ~ 315
1LE0003- □□□□ 9-0 □□□□ -Z	M2F	460VD 60Hz (50Hz output, 50Hz 功率输出)	FS80 ~ 315
1LE0003- □□□□ 9-0 □□□□ -Z	X04	480VY 60Hz (60Hz output, 60Hz 输出)	FS80 ~ 315
1LE0003- □□□□ 9-0 □□□□ -Z	X20	480VD 60Hz (60Hz output, 60Hz 输出)	FS80 ~ 315
绕组保护 Motor protection			
1LE0003- □□□□□□ - □□ A □ ²⁾		无绕组保护 Without motor protection	FS80 ~ 315
1LE0003- □□□□□□ - □□ B □		绕组带一组三芯串联的 PTC 热敏电阻用于跳闸 Motor protection with PTC thermistors with three embedded temperature sensors for tripping	FS80 ~ 315

电动机订货号 Motor order code	选件号 Option Code ¹⁾	描述 Description	应用范围 Application Scope
绕组保护 Motor protection			
1LE0003- □□□□□□ - □□ C □		绕组带两组三芯串联的 PTC 热敏电阻用于报警和跳闸 Motor protection with PTC thermistors with six embedded temperature sensors for alarm & tripping	FS80 ~ 315
1LE0003- □□□□□□ - □□ F □		绕组带一个 KTY 84-130 温度传感器 Motor temperature detection with embedded temperature sensor KTY84-130	FS100 ~ 315
1LE0003- □□□□□□ - □□ H □		绕组带 3 个 Pt100 测温元件 Installation of three PT100 resistance thermometers	FS80 ~ 315
1LE0003- □□□□□□ - □□ J □		绕组带 6 个 Pt100 测温元件 Installation of six PT100 resistance thermometers	FS80 ~ 315
线圈和绝缘 Windings and insulation			
—	N01	温度等级 155 (F)，使用 155 (F)，带有服务系数 (SF1.15) Temperature class 155 (F), used according to 155 (F), with service factor (SF1.15)	FS80 ~ 315
—	N10	180 (H) 度温度等级绝缘 Temperature class 180 (H)	FS80 ~ 315
—	Q04	绕组带 220 V 防潮加热带 Anti-condensation heater for 220 VAC (spaces heater)	FS80 ~ 315
电动机接线盒 Motor connection box			
1LE0003- □□□□□□ - □□□□ 4 ²⁾		接线盒在顶端 Connection box on top	FS80 ~ 315
		进线孔在右侧 (从驱动端看) (标准电动机) cable entry on right (view from DE) (Standard version)	FS80 ~ 315
1LE0003- □□□□□□ - □□□□ 5		接线盒在右边 (从驱动端看) Connection box on RHS (view from DE)	FS80 ~ 315
1LE0003- □□□□□□ - □□□□ 6		接线盒在左边 (从驱动端看) Connection box on LHS (view from DE)	FS80 ~ 315
—	R10 ³⁾	接线盒直接旋转 90°，进线口朝向驱动端 Rotation of the connection box through 90°, entry from DE	FS80 ~ 315
—	R11	接线盒直接旋转 90°，进线口朝向非驱动端 Rotation of the connection box through 90°, entry from NDE	FS80 ~ 315
—	R12	接线盒直接旋转 180° Rotation of the connection box through 180°	FS80 ~ 315
—	H08 ⁴⁾	接线盒在非驱动端 Connection box on NDE	FS80 ~ 315
—	L97	辅助接线盒 Additional connection box	FS200 ~ 315

选件 Options

电动机订货号 Motor order code	选件号 Option Code ¹⁾	描述 Description	应用范围 Application Scope
轴承 Bearings			
	L80 ⁵⁾	SKF 轴承 SKF Bearing	FS80 ~ 315
	L22 ⁶⁾	增强悬臂力轴承设计 Bearing design for increased cantilever forces	FS100 ~ 315
	L23 ⁷⁾	再润滑装置 Regreasing device	FS100 ~ 250
	Q5A	轴承带两个 PT100 测温元件 Installation of 2PT100 screw-in resistance thermometers for bearing	FS180 ~ 315
	L27 ⁸⁾	绝缘轴承 Insulated bearing	FS250 ~ 315
	Q01	驱动端预留 SPM 测量接头 Measuring nipple for SPM shock pulse at DE measurement for bearing inspection	FS100 ~ 315
平衡 Balance and vibration quantity			
	L00	B 级振动等级 Vibration quantity level B	FS80 ~ 315
机械设计和防护等级 Mechanical design and degrees of protection			
	L05 ^{9) 10)}	第二标准轴伸 Second standard shaft extension	FS80 ~ 315
	H00 ¹¹⁾	电动机带防护罩 Motor with protective cover	FS80 ~ 315
	H03 ¹²⁾	冷凝水排放孔 Condensation drainage holes	FS80 ~ 315
	H04	外部接地 External earthing	FS80 ~ 280
	H22	IP56 防护等级 (非高海况) IP56 degree of protection (non-heavy-sea)	FS80 ~ 315
模块化技术 Modular technology			
	F70 ¹³⁾	IC 416 冷却方式 (非自冷), 电动机带独立驱动风扇 Mounting of separately driven fan	FS80 ~ 315
	F90 ¹⁴⁾	风机电机 (无风扇和风扇罩, 非驱动端全封闭) Fan motor (Without fan and fan cover, NDE closed)	FS80 ~ 315
	F76	金属风扇 Metal fan	FS80 ~ 315
	X05	预留安装 LL861900220 编码器位置 Prepared for of LL861900220 encoder	FS112 ~ 315
	G04	安装编码器 LL861900200 Mounting of LL861900220 rotary pulse encoder	FS112 ~ 315
	X50 ¹⁵⁾	安装欧姆龙编码器 (E6B2-CWZ6C) 和独立驱动风扇 Mounting of Omron rotary pulse encoder (E6B2-C) and separately driven fan	FS80 ~ 315
	W74 ¹⁶⁾	安装欧姆龙编码器 (E6B2-CWZ1X) 和独立驱动风扇 Mounting of Omron encoder (E6B2-CWZ1X) and separated driven fan	FS80 ~ 315
铭牌和测试证书 Rating plate and test certificates			
	B02	出厂检验报告 Acceptance test certificate 3.1 in accordance with EN 10204	FS80 ~ 315

电动机订货号 Motor order code	选件号 Option Code ¹⁾	描述 Description	应用范围 Application Scope
喷漆 Paint finish			
	S01	不喷漆, 只带底漆 Unpainted, only primed	FS80 ~ 315
	S80	标准喷漆, 颜色为 RAL 7032 Standard finish in RAL 7032	FS80 ~ 315
	S81	标准喷漆, 颜色为 RAL 9006 Standard finish in RAL 9006	FS80 ~ 315
	W88 ¹⁷⁾	适用 TH, W, F1, WF1 以及海洋性气候环境用电机 Design for TH, W, F1, WF1 and Sea air resistant	FS80 ~ 315
环境温度 Coolant temperature			
	D03	用于环境温度 -40 °C ~ +40 °C 下使用的电机 Coolant temperature -40 °C to + 40 °C	FS80 ~ 315

- ¹⁾ 订货时, 电动机订货号需带“-Z”, 另外附上选件号;
- ²⁾ 无需附加费用;
- ³⁾ 对于 FS80 ~ 112 电动机只有接线盒在非驱动端 (选件号: H08) 时, 才可以选此选件;
- ⁴⁾ 进线孔方向朝向驱动端;
- ⁵⁾ 机座号 250 及以上、立式安装的电机选择此选件时需要特殊询价; 与选件 L22 同时选择时, 需要特殊询价。
- ⁶⁾ 对于立式安装的 FS250~FS315 电动机, 需要特殊咨询西门子。
- ⁷⁾ 对于 FS280, FS315, 加排油装置是标配;
- ⁸⁾ 对于水平安装的电机, 绝缘轴承放置非驱动端。对于立式安装的电机, 当后端是角接触轴承时, 绝缘轴承放置在驱动端;
- ⁹⁾ 带防雨罩或独立驱动风扇的电动机不能选此选件;
- ¹⁰⁾ 非驱动端上的第二轴尺寸与驱动端轴申不一致;
- ¹¹⁾ 仅适用于 IM V5、IM V1、IMV15 以及 IM V18 安装结构型式。无法与选件号 L05 并用;
- ¹²⁾ 适用于水平安装电机; 对于立式安装的电机, 请向西门子咨询。电动机安装排水孔时, 须在购买电动机时注明其具体安装方式;
- ¹³⁾ 当安装独立风机时, 电动机的长度将增加 ΔL 。具体的增加尺寸和技术数据请查看第 8 页内容;
- ¹⁴⁾ 无风扇和风罩时, 电动机的长度将减小 Δl 。按照铭牌上功率数值输出时, 电动机必须有外部冷却。客户应当采用正确的冷却方式, 没有或错误的冷却方式都将减少电动机的使用寿命, 甚至会损坏电动机;
- ¹⁵⁾ SINAMICS 变频器联结 Omron 编码器 (E6B2-CWZ6C) 时, 变频器需要一些特殊配置。详细信息, 请咨询西门子热线。
- ¹⁶⁾ SINAMICS 变频器可以直接与 Omron 编码器 (E6B2-CWZ1X) 联结。
- ¹⁷⁾ 可用于室内、或暴露环境中的的室外安装, 也可用于含有中等浓度 SO₂ 的工业环境中, 并可用于海洋性气候环境中, 但不适用于海上的应用。

- ¹⁾ Order No. supplement Z with option code when ordering;
- ²⁾ Without additional charge
- ³⁾ For FS80 ~ 112 motor, R10 only in combination with Option code H08 (Connection box on NDE) possible.
- ⁴⁾ Cable entry on connection box towards the non-drive end.
- ⁵⁾ On request for FS250 and above motors in vertical mounting; On request for motors configured with option L22.
- ⁶⁾ For vertical mounting of FS250~FS315 motor, please specially consult with Siemens.
- ⁷⁾ FS280, FS315 motor with the regrease device as standard.
- ⁸⁾ For horizontal mounting motor, insulated bearing located at DE; For vertical mounting motor, insulated bearing located at NDE.
- ⁹⁾ Not possible in combination with canopy or separately driven fan (Order code: F70).
- ¹⁰⁾ Second standard shaft extension on NDE has allowed output from the next smaller frame size.
- ¹¹⁾ Only applicable for the construction type IM V5, IM V1, IM V15 and IM V18. Not possible in combination with Option code L05.
- ¹²⁾ Applicable to motor of horizontal mounting. If vertical mounting motor required to be with condensation drainage holes, please inquiry Siemens specially. If condensation drainage holes are required, it is necessary to order the motors in their respective type of construction.
- ¹³⁾ When the separately driven fan is mounted, the length of the motor increase by ΔL . For an explanation of the additional dimension and technical data see from page 8.
- ¹⁴⁾ Without fan and fan cover, the length of the motor is decrease by Δl . By using the power output of rating plate, the motor must have external cooling by air flow. The correct motor cooling is in responsibility of customer. Missing or wrong cooling reduce the life time or damaged the motor.
- ¹⁵⁾ When SINAMICS inverter is connected with Omron encoder (E6B2-CWZ6C), additional configuration on inverter is needed. For detailed information, please contact with Siemens hotline.
- ¹⁶⁾ Omron encoder (E6B2-CWZ1X) can be directly connected with SINAMICS inverter.
- ¹⁷⁾ Recommended for indoor or outdoor installations exposed to direct weather conditions. Industrial environment with moderate SO₂, inshore maritime climate but not offshore.

外形尺寸 Dimension drawings

1LE0003 铸铁系列电机 Cast-iron series 1LE0003

机座号从 80M~160L Frame sizes 80 M to 160L

IM B3 安装结构方式 Type of construction IM B3

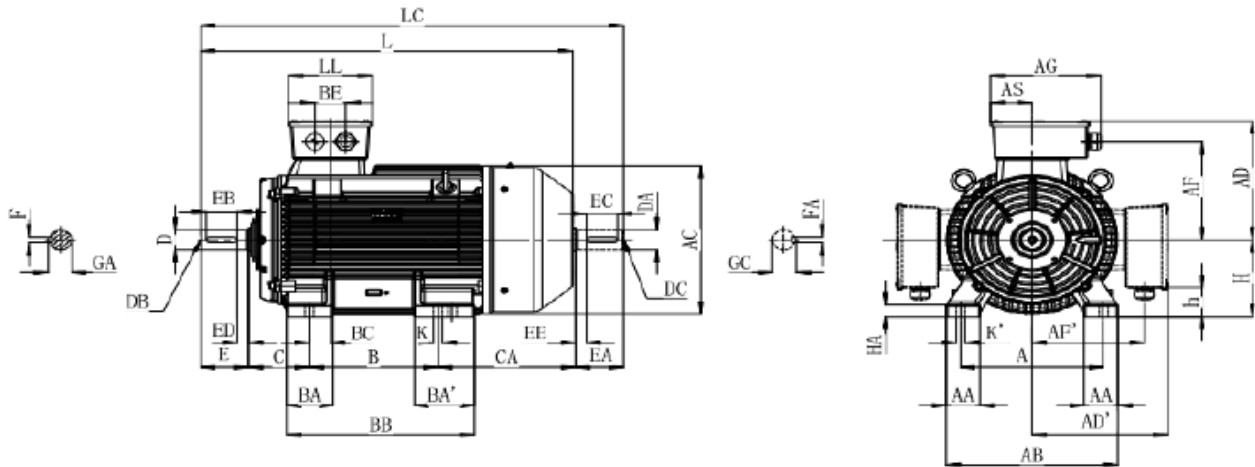

IM B35 安装结构方式 Type of construction IM B35

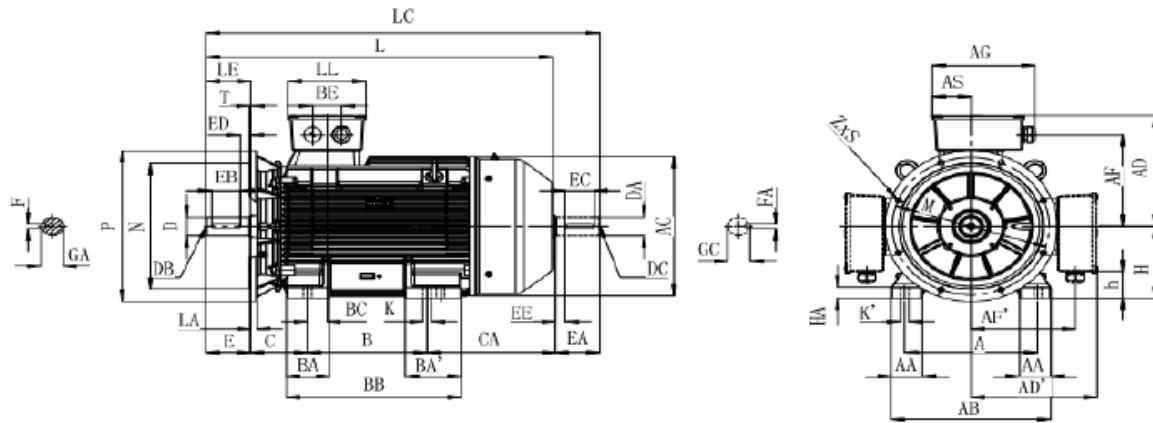

机座号 Frame size	类型 Type 1LE0003-	极数 poles	尺寸图依据 IEC 标准 Dimension designation according to IEC standards																
			A	AA	AB	AC1)	A D / AD'	A F / AF'	AG	AH	AS	B2)	B A / BA'	BB	BC	BE	C	CA2)	H
80 M	0D □ 2	2	125	36	160	157	142	110.5	145	-	65.5	100	44	135	26	42	50	143	80
	0D □ 2	4, 6	125	36	160	157	142	110.5	145	-	65.5	100	44	135	26	42	50	143	80
	0D □ 3	2, 4, 6	125	36	160	157	142	110.5	145	-	65.5	100	44	135	26	42	50	143	80
90 S	0E □ 0	2, 4, 6	140	46	175	175	152	120.5	145	-	65.5	100	46	140	20	42	56	165	90
90 L	0E □ 4		140	46	175	175	152	120.5	145	-	65.5	125	46	165	20	42	56	165	90
100 L	1A □ 4	2, 4, 6	160	45	200	196	177	140	163	276	70	140	45	176	30.5	54	63/783)	203.5	100
	1A □ 5	4	160	45	200	196	177	140	163	276	70	140	45	176	30.5	54	63/783)	203.5	100
112 M	1B □ 2	2, 4, 6	190	45	226	221	188.5	152	163	304	70	140	50	180	22	54	70	182	112
132 S	1C □ 0	2, 4, 6	216	50	256	259	212	175	163	354	70	140	64	186	32.5	54	89/1043)	213	132
	1 □ 1	2	216	50	256	259	212	175	163	354	70	140	64	186	32.5	54	89/1043)	213	132
132 M	1C □ 2	4, 6	216	50	256	259	212	175	163	354	70	178	64	224	32.5	54	89/1113)	220	132
	1C □ 3	6	216	50	256	259	212	175	163	354	70	178	64	224	32.5	54	89/1113)	220	132
160 M	1D □ 2	2, 4, 6	254	60	314	312	255	206	231	422	94	210	70	258	51	68	108/1123)	193	160
	1D □ 3	2	254	60	314	312	255	206	231	422	94	210	70	258	51	68	108/1123)	193	160
160 L	1D □ 4	2, 4, 6	254	60	314	312	255	206	231	422	94	254	70	302	51	68	108/1283)	209	160

¹⁾ 包含螺栓头的尺寸

²⁾ 该尺寸为 DIN EN 50347 标准所列机座号对应尺寸

³⁾ 仅适用于配置 H08 选件的电机

IM B5 以及 IM V1 安装方式 Type of construction IM B5 and IM V1

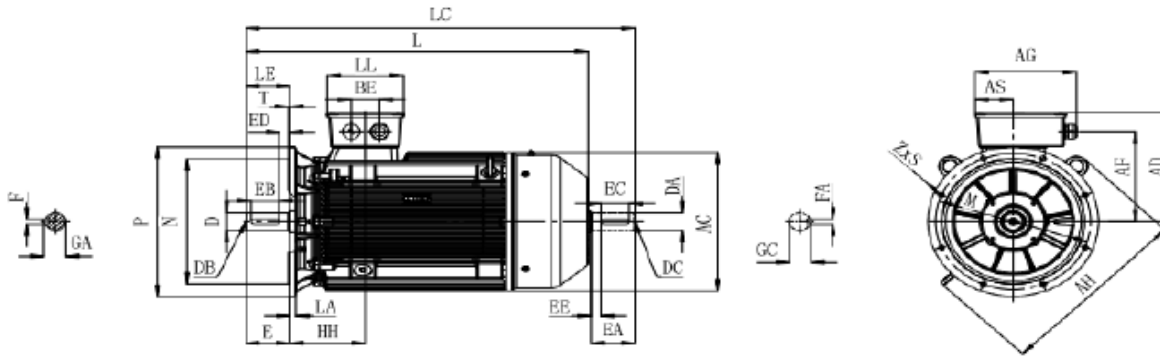

IM B14 安装方式 Type of construction IM B14

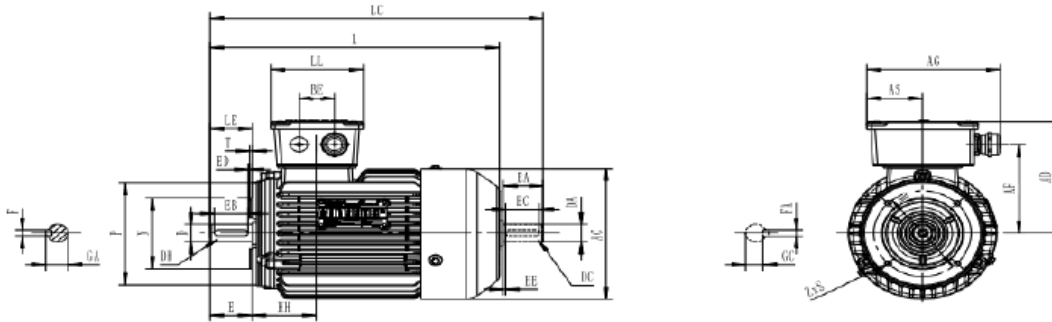

							驱动端轴伸直径 DE shaft extension							非驱动端轴伸 (选项号为 L05) NDE shaft extension (option code L05)						
h	HA	HH	K / K'	L	LC	LL	D	DB	E	EB	ED	F	GA	DA	DC	EA	EC	EE	FA	GC
14.5	10	76	10	328	363	109	19	M6	40	32	4	6	21.5	14	M5	30	22	4	5	16
14.5	10	76	10	328	363	109	19	M6	40	32	4	6	21.5	14	M5	30	22	4	5	16
14.5	10	76	10	328	363	109	19	M6	40	32	4	6	21.5	14	M5	30	22	4	5	16
24.5	10	76	10	366	411	109	24	M8	50	40	5	8	27	19	M6	40	32	5	8	21.5
24.5	10	76	10	391	436	109	24	M8	50	40	5	8	27	19	M6	40	32	5	8	21.5
30	12	93.5	12	460	516.5	118	28	M10	60	50	5	8	31	24	M8	50	40	5	8	27
30	12	93.5	12	460	516.5	118	28	M10	60	50	5	8	31	24	M8	50	40	5	8	27
42	12	92	12	448	502	118	28	M10	60	50	5	8	31	24	M8	50	40	5	8	27
62	15	121.5	12	515	582	118	38	M12	80	70	5	10	41	28	M10	60	50	5	8	31
62	15	121.5	12	515	582	118	38	M12	80	70	5	10	41	28	M10	60	50	5	8	31
62	15	121.5	12	560	627	118	38	M12	80	70	5	10	41	28	M10	60	50	5	8	31
62	15	121.5	12	560	627	118	38	M12	80	70	5	10	41	28	M10	60	50	5	8	31
66	20	159	15	614	701	158	42	M16	110	100	5	12	45	38	M12	80	70	5	10	41
66	20	159	15	614	701	158	42	M16	110	100	5	12	45	38	M12	80	70	5	10	41
66	20	159	15	674	761	158	42	M16	110	100	5	12	45	38	M12	80	70	5	10	41

¹⁾ Measured across the bolt heads.

²⁾ This dimension is assigned in DIN EN 50347 to the frame size listed.

³⁾ Only for the motor configured with H08 option

外形尺寸 Dimension drawings

1LE0003 铸铁系列电机 Cast-iron series 1LE0003

机座号从 180 M ~ 315L Frame sizes 180 M ~ 315 L

IM B3 安装结构方式 Type of construction IM B3

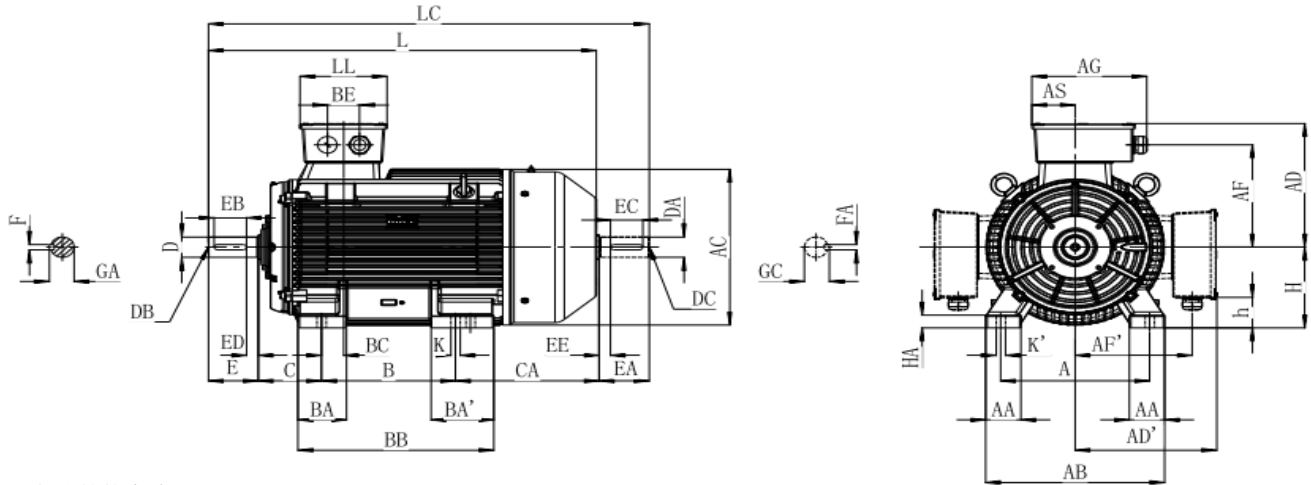

IM B35 安装结构方式 Type of construction IM B35

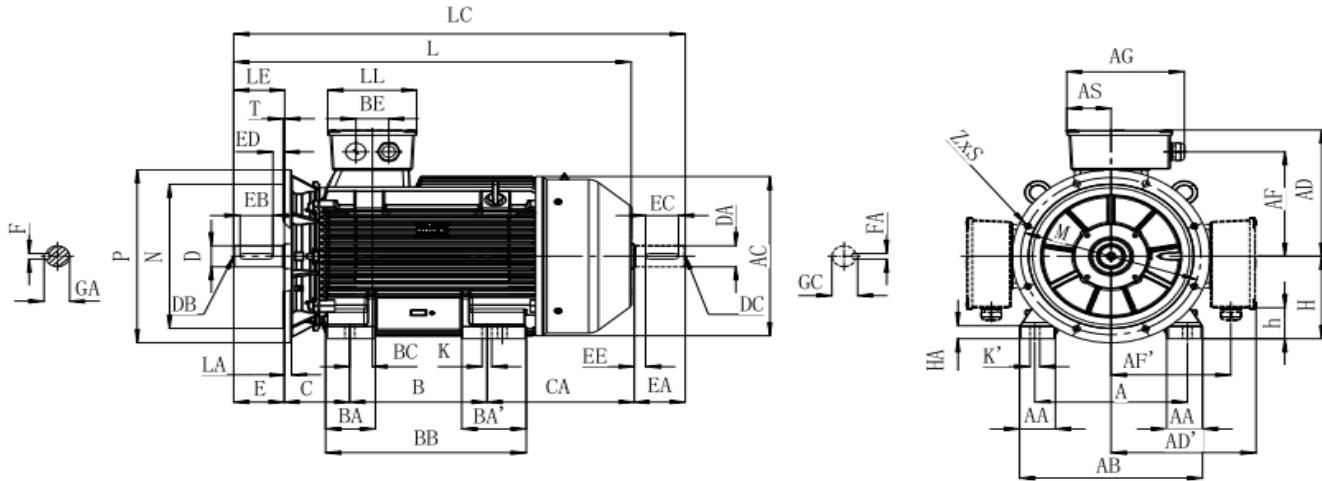

机座号 Frame size	类型 Type 1LE0003-	极数 poles	尺寸图依据 IEC 标准 Dimension designation according to IEC standards														
			A	AA	AB	AC ¹⁾	AD / AD'	AF / AF'	AG	AH	AS	B ²⁾	BA / BA'	BB	BC	BE	C
180M	1E □ 2	2,4	279	65	339	356	270	221	231	466	94	241	80	301	37	68	121/150 ³⁾
180L	1E □ 4	4,6	279	65	339	356	270	221	231	466	94	279	80	339	37	68	121/152 ³⁾
200L	2A □ 4	2,4,6	318	70	378	397	300	247.5	288	532	107.5	305	80	369	69	85	133/158 ³⁾
	2A □ 5	2,6	318	70	378	397	300	247.5	288	532	107.5	305	80	369	69	85	133/158 ³⁾
225S	2B □ 0	4	356	80	436	442	327	274	288	556	107.5	286	90	348	63	85	149/136 ³⁾
225M	2B □ 2	2	356	80	436	442	327	274	288	556	107.5	311	90	373	63	85	149/166 ³⁾
		4,6															
250M	2C □ 2	2 4,6	406	90	490	488	373	310.5	342	600	123	349	100	421	92	84	168/208 ³⁾
280S	2D □ 0	2 4,6	457	100	540	538	413	350.5	342	652	123	368	115	454	72	84	190/172 ³⁾
280M	2D □ 2	2 4,6	457	100	540	538	413	350.5	342	652	123	419	115	505	72	84	190/172 ³⁾
315S	3A □ 0	2 4,6	508	120	610	608	482	401	401	734	148	406	140	520	75	110	216/230 ³⁾
315M	3A □ 2	2 4,6	508	120	610	608	482	401	401	734	148	457/508	165/215	668	75	110	216/409 ³⁾
315L	3A □ 5/3A 6/3A □ 7	2 4,6	508	120	610	608	482	401	401	734	148	457/508	165/215	668	75	110	216/358 ³⁾

¹⁾ 包含螺栓头的尺寸

²⁾ 该尺寸为 DIN EN 50347 标准所列机座号对应尺寸

³⁾ 仅适用于配置 H08 选件的电机

IM B5 以及 IM V1 安装方式 Type of construction IM B5 and IM V1

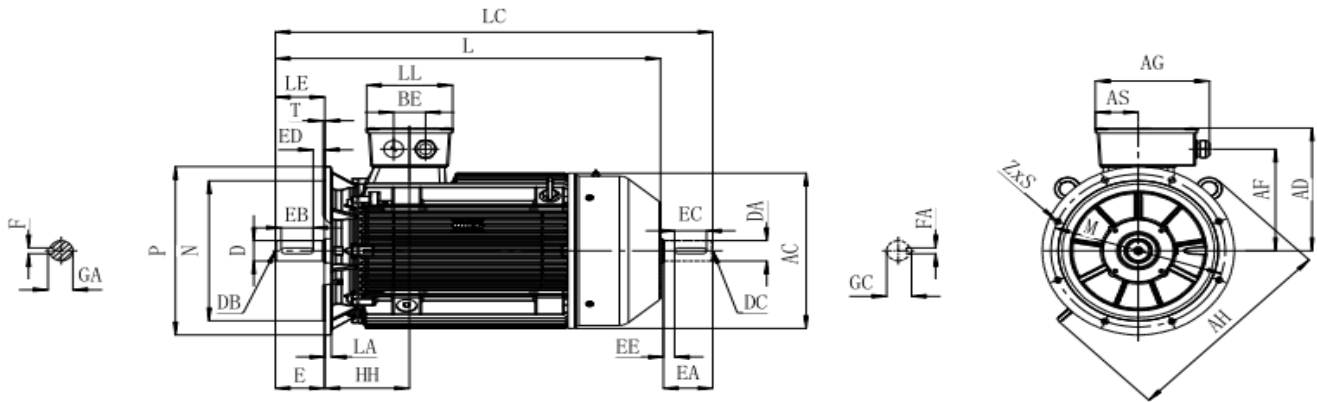

		驱动端轴伸直径 DE shaft extension															非驱动端轴伸 (选项号为 L05) NDE shaft extension (option code L05)						
	CA ²⁾	H	h	HA	HH	K/ K'	L	LC	LL	D	DB	E	EB	ED	F	GA	DA	DC	EA	EC	EE	FA	GC
	246	180	86	20	158	15	718	836	158	48	M16	110	100	5	14	51.5	42	M16	110	90	10	12	45
	248	180	86	20	158	15	758	876	158	48	M16	110	100	5	14	51.5	42	M16	110	90	10	12	45
	259	200	64.5	25	202	19	807	927	215	55	M20	110	100	5	16	59	48	M16	110	100	5	14	51.5
	259	200	64.5	25	202	19	807	927	215	55	M20	110	100	5	16	59	48	M16	110	100	5	14	51.5
	245	225	89.5	34	212	19	845	965	215	60	M20	140	125	10	18	64	55	M20	110	100	5	16	59
	275	225	89.5	34	212	19	820	940	215	55	M20	110	100	5	16	59	48	M16	110	100	5	14	51.5
							875	995		60		140	125	10	18	64	55	M20	110	100	5	16	59
	309	250	81	40	260	24	967	1087	246	60	M20	140	125	10	18	64	55	M20	110	100	5	16	59
								1117		65						69	60	M20	140	125	10	18	64
	293	280	111	40	262	24	991	1141	246	65	M20	140	125	10	18	69	60	M20	140	125	10	18	64
										75				10	20	79.5	65	M20	140	125	10	18	69
	293	280	111	40	262	24	1042	1192	246	65	M20	140	125	10	18	69	60	M20	140	125	10	18	64
										75				10	20	79.5	65	M20	140	125	10	18	69
	401	315	111	50	291	28	1163	1315	296	65	M20	140	125	10	18	69	65	M20	140	125	10	18	69
							1193	1545		80		170	140	25	22	85	75	M20	140	125	10	20	79.5
	580	315	111	50	291	28	1393	1345	296	65	M20	140	125	10	18	69	65	M20	140	125	10	18	69
							1423	1575		80		170	140	25	22	85	75	M20	140	125	10	20	79.5
	529	315	111	50	291	28	1393	1345	296	65	M20	140	125	10	18	69	65	M20	140	125	10	18	69
							1423	1575		80		170	140	25	22	85	75	M20	140	125	10	20	79.5

¹⁾ Measured across the bolt heads.

²⁾ This dimension is assigned in DIN EN 50347 to the frame size listed.

³⁾ Only for the motor configured with H08 option

外形尺寸 Dimension drawings

法兰尺寸 Flange dimension

IM B5、IM B35、IM V1、IM V3 安装结构型式
Type of construction IM B5, IM B35, IM V1, IM V3

IM B14、IM V18、IM V19 安装结构型式
Type of construction IM B14, IM V18, IM V19

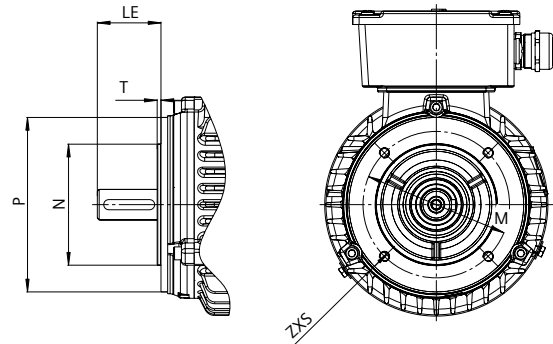
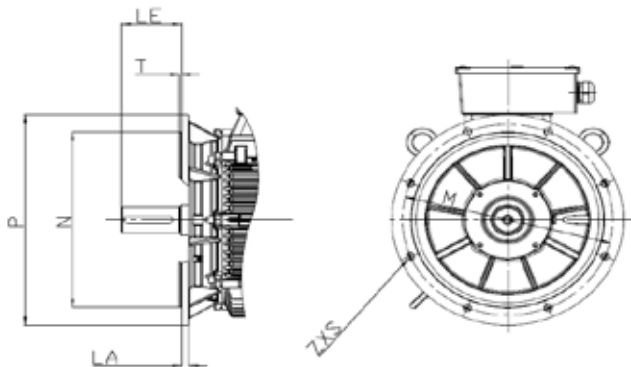

机座号 Frame size	安装方式 Type of construction	法兰带通孔 (FF/A)/ 带内螺纹孔 (FT/C) Flange with Through holes(FF/A) Tapped holes(FT/C)	尺寸图依据 IEC 标准 Dimension designation according to IEC standards							
		按照 DIN EN 50347 标准 According to DIN EN 50 347	LA	LE	M	N	P	S	T	Z
80	IM B5, IM B35, IM V1, IM V3 IM B14, IM V18, IM V19	FF 165	10	40	165	130	200	12	3.5	4
		FT 100	—	40	100	80	120	M 6	3	4
90	IM B5, IM B35, IM V1, IM V3 IM B14, IM V18, IM V19	FF 165	10	50	165	130	200	12	3.5	4
		FT 115	—	50	115	95	140	M 8	3	4
100	IM B5, IM B35, IM V1, IM V3 IM B14, IM V18, IM V19	FF 215	11	60	215	180	250	14.5	4	4
		FT 130	—	60	130	110	160	M 8	3.5	4
112	IM B5, IM B35, IM V1, IM V3 IM B14, IM V18, IM V19	FF 215	11	60	215	180	250	14.5	4	4
		FT 130	—	60	130	110	160	M 8	3.5	4
132	IM B5, IM B35, IM V1, IM V3 IM B14, IM V18, IM V19	FF 265	14	80	265	230	300	14.5	4	4
		FT 165	—	80	165	130	200	M 10	3.5	4
160	IM B5, IM B35, IM V1, IM V3 IM B14, IM V18, IM V19	FF 300	14	110	300	250	350	18.5	5	4
		FT 215	—	110	215	180	250	M 12	4	4
180	IM B5, IM B35, IM V1, IM V3	FF 300	16	110	300	250	350	18.5	5	4
200	IM B5, IM B35, IM V1, IM V3	FF 350	16	110	350	300	400	18.5	5	4
225	IM B5, IM B35, IM V1, IM V3	FF 400	16	110/140	400	350	450	18.5	5	8
250	IM B5, IM B35, IM V1, IM V3	FF 500	18	140	500	450	550	18.5	5	8
280	IM B5, IM B35, IM V1, IM V3	FF 500	18	140	500	450	550	18.5	5	8
315	IM B5, IM B35, IM V1, IM V3	FF 600	22	140/170	600	550	660	24	6	8

认证 Certificates



北方区

北京

北京市朝阳区望京中环南路7号
电话: 400 616 2020

包头

内蒙古自治区包头市昆区钢铁大街74号
财富中心1905室
电话: (0472) 520 8828

济南

山东省济南市舜耕路28号
舜耕山庄商务会所5层
电话: (0531) 8266 6088

青岛

山东省青岛市香港中路76号
颐中假日酒店4楼
电话: (0532) 8573 5888

烟台

山东省烟台市南大街9号
金都大厦16层1606室
电话: (0535) 212 1880

淄博

山东省淄博市张店区中心路177号
淄博饭店7层
电话: (0533) 218 7877

潍坊

山东省潍坊市奎文区四平路31号
舜飞大酒店1507房间
电话: (0536) 822 1866

济宁

山东省济宁市高新区火炬路19号
香港大厦361房间
电话: (0537) 239 6000

天津

天津市和平区南京路189号
津汇广场写字楼1401室
电话: (022) 8319 1666

唐山

河北省唐山市建设北路99号
火炬大厦1308室
电话: (0315) 317 9450/51

石家庄

河北省石家庄市中山东路303号
世贸广场酒店1309号
电话: (0311) 8669 5100

太原

山西省太原市府西街69号
国际贸易中心西塔16层1609B-1610室
电话: (0351) 868 9048

呼和浩特

内蒙古呼和浩特市乌兰察布西路
内蒙古饭店10层1022室
电话: (0471) 620 4133

东北区

沈阳

辽宁省沈阳市沈河区北站路59号
财富大厦E座12-14层
电话: (024) 8251 8111

大连

辽宁省大连市高新园区
七贤岭广贤路117号
电话: (0411) 8369 9760

长春

吉林省长春市亚泰大街3218号
通钢国际大厦22层
电话: (0431) 8898 1100

哈尔滨

黑龙江省哈尔滨市南岗区红军街15号
奥威斯发展大厦30层A座
电话: (0451) 5300 9933

华西区

成都

四川省成都市高新区拓新东街81号
天府软件园C6栋1/2楼
电话: (028) 6238 7888

重庆

重庆市渝中区邹容路68号
大都会商厦18层1807-1811
电话: (023) 6382 8919

贵阳

贵州省贵阳市南明区花果园后街
彭家湾E7栋(国际金融街1号)
14楼01&02室
电话: (0851) 8551 0310

昆明

云南昆明市北京路155号
红塔大厦1204室
电话: (0871) 6315 8080

西安

西安市高新区锦业一路11号
西安国家服务外包示范基地一区D座3层
电话: (029) 8831 9898

乌鲁木齐

新疆乌鲁木齐市五一一路160号
新疆鸿福大饭店贵宾楼918室
电话: (0991) 582 1122

银川

银川市北京东路123号
太阳神大酒店A区1507房间
电话: (0951) 786 9866

兰州

甘肃省兰州市东岗西路589号
锦江阳光酒店2206室
电话: (0931) 888 5151

华东区

上海

上海杨浦区大连路500号
西门子上海中心
电话: 400 616 2020

杭州

浙江省杭州市西湖区杭大路15号
嘉华国际商务中心1505室
电话: (0571) 8765 2999

宁波

浙江省宁波市江东区沧海路1926号
上东国际2号楼2511室
电话: (0574) 8785 5377

绍兴

浙江省绍兴市解放北路
玛格丽特商业中心西区2幢
玛格丽特酒店10层1020室
电话: (0575) 8820 1306

温州

浙江省温州市车站大道
高联大厦9层B1室
电话: (0577) 8606 7091

南京

江苏省南京市中山路228号
地铁大厦17层
电话: (025) 8456 0550

扬州

江苏省扬州市文昌西路56号
公元国际大厦809室
电话: (0514) 8789 4566

扬中

江苏省扬中市前进北路52号
扬中宾馆明珠楼318室
电话: (0511) 8832 7566

徐州

江苏省徐州市泉山区中山北路29号
国贸大厦7A7室
电话: (0516) 8370 8388

苏州

江苏省苏州市新加坡工业园苏华路2号
国际大厦11层17-19单元
电话: (0512) 6288 8191

无锡

江苏省无锡市县前东街1号
金陵大酒店2401-2402室
电话: (0510) 8273 6868

南通

江苏省南通市崇川区桃园路8号
中南世纪城17栋1104室
电话: (0513) 8102 9880

常州

江苏省常州市关河东路38号
九洲寰宇大厦911室
电话: (0519) 8989 5801

盐城

江苏省盐城市盐都区
华邦国际大厦A区2008室
电话: (0515) 8836 2680

昆山

江苏省昆山市伟业路18号
昆山现代广场A座1019室
电话: (0512) 55118321

华南区

广州

广东省广州市天河路208号
天河城侧粤海天河城大厦8-10层
电话: (020) 3718 2222

佛山

广东省佛山市汾江中路121号
东建大厦19楼K单元
电话: (0757) 8232 6710

珠海

广东省珠海市景山路193号
珠海石景山旅游中心229房间
电话: (0756) 337 0869

南宁

广西省南宁市金湖路63号
金源现代城9层935室
电话: (0771) 552 0700

深圳

广东省深圳市南山区华侨城
汉唐大厦9楼
电话: (0755) 2693 5188

东莞

广东省东莞市南城区宏远路1号
宏远大厦1510室
电话: (0769) 2240 9881

汕头

广东省汕头市金砂路96号
金海湾大酒店19楼1920室
电话: (0754) 8848 1196

海口

海南省海口市滨海大道69号
宝海海景大酒店803房
电话: (0898) 6678 8038

福州

福建省福州市五四路89号
置地广场11层04、05单元
电话: (0591) 8750 0888

厦门

福建省厦门市厦禾路189号
银行中心21层2111-2112室
电话: (0592) 268 5508

华中区

武汉

湖北省武汉市武昌区中南路99号
武汉保利大厦21楼2102室
电话: (027) 8548 6688

合肥

安徽省合肥市濉溪路278号
财富广场首座27层2701-2702室
电话: (0551) 6568 1299

宜昌

湖北省宜昌市东山大道95号
清江大厦2011室
电话: (0717) 631 9033

长沙

湖南省长沙市五一大道456号
亚太时代写字楼2101、2101-2室
电话: (0731) 8446 7770

南昌

江西省南昌市北京西路88号
江信国际大厦14楼1403/1405室
电话: (0791) 8630 4866

郑州

河南省郑州市中原区中原中路220号
裕达国贸中心写字楼2506房间
电话: (0371) 6771 9110

洛阳

河南省洛阳市涧西区西苑路6号
友谊宾馆516室
电话: (0379) 6468 3519

技术培训

北京: (010) 6476 8958
上海: (021) 6281 5933-305/307/308
广州: (020) 3810 2015

武汉: (027) 8548 6688-6400
沈阳: (024) 2294 9880/8251 8219
重庆: (023) 6382 8919-3002

技术支持与服务热线

电话: 400 810 4288
(010) 6471 9990
E-mail: 4008104288.cn@siemens.com
Web: www.4008104288.com.cn

亚太技术支持(英文服务)

及软件授权维修热线
电话: (010) 6475 7575
传真: (010) 6474 7474
Email: support.asia.automation@siemens.com

公司热线

北京: 400 616 2020

直接扫描
获得本书
PDF文件

更多信息
请访问



西门子(中国)有限公司
过程工业与驱动集团

如有变动, 恕不事先通知
订货号: PDL-D80002-00-5DCN
744-SH902810-101510

西门子公司版权所有

本宣传册中提供的信息只是对产品的一般说明和特性介绍。文中内容可能与实际应用的情况有所出入, 并且可能会随着产品的进一步开发而发生变化。仅当相关合同条款中有明确规定时, 西门子方有责任提供文中所述的产品特性。

宣传册中涉及的所有名称可能是西门子公司或其供应商的商标或产品名称, 如果第三方擅自使用, 可能会侵犯所有者的权利。